

POWER TAKE-OFF 3.2.79.9.

FOR GEARBOX :

HINO H 350 DUTRO



Technical data: refer to transmission application manual.

OUTPUT TORQUE:

25 kgm. (increase of 50% for intermittent service).

WEIGHT: kg. 9,3

3.2.79.9.X.XX.1.X

BASIC SERIAL NUMBER _____

COMPANION FLANGE FOR REMOTE TRANSMISSION

0=NOOPTION

1=SPICER 1120 CODE 2.05.054.0000

2=SPICER 1300 CODE 2.05.055.0000

3=DIN 00 CODE 2.05.056.0000

6=DIN 10 CODE 2.05.077.0000

VERSION _____

OUTPUT SHAFT OPTION

1=PNEUMATIC CONTROL

3=MECHANICAL PUSH-PULL CONTROL

5=VACUUM CONTROL

OUTPUT SHAFT OPTION

DESCRIPTION	CODE	
	SIDE A	SIDE B
For remote transmission (see chart X group A)	*01	02
Direct mounting PZB pumps-3 bolt mtg. flange (see chart Y type A)	*03	04

* Output shaft option SIDE A **only** for pneumatic and mechanical push-pull control.

DETAIL VACUUM CONTROL

DETAIL PNEUMATIC SHIFTING

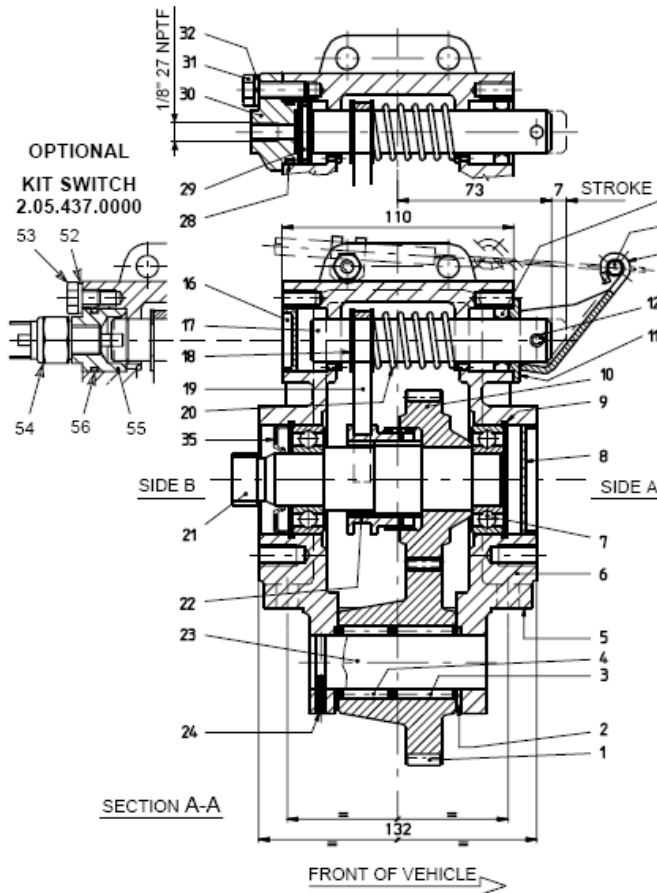

MANUAL TIGHTENING, WITHOUT TOOLS

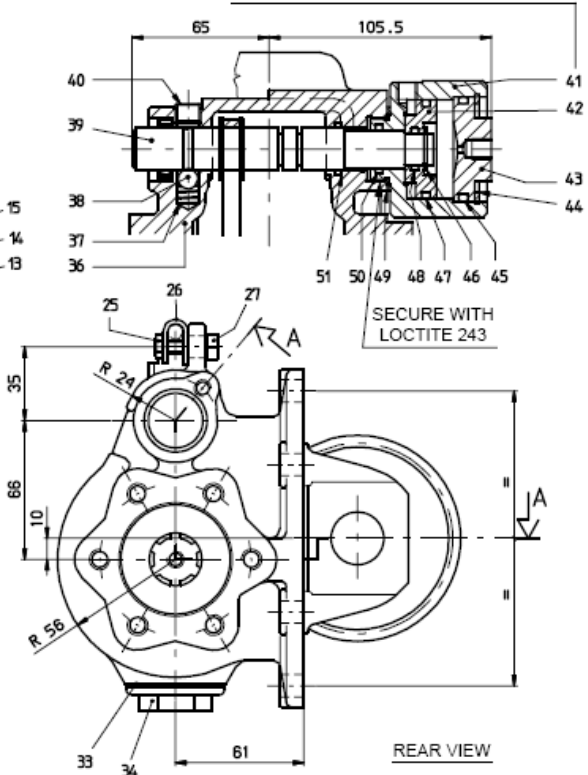

REF.	CODE	DESCRIPTION	QT.
1	1.11.01.189.00	Gear 36 T	1
2	1.27.01.033.00	Washer 43x25,2x2	2
3	0.10.06.007.00	Needle cage K25x35x30	1
4	0.10.06.008.00	Needle cage K25x35x25	1
5	1.29.01.001.00	Gasket PTO/gearbox SAE 6-bolt/metr.0,5	1
6	1.01.02.090.00	Housing (PTO 3.2.79.9.1 - 3.2.79.9.3)	1
7	0.10.01.017.00	Bearing 6205-2RS	2
8	0.12.01.044.00	Screw plug 52x7	1
9	0.07.02.004.00	Circlip 52i UNI 7437	2
10	1.11.10.155.00	Gear 31 T	1
11	1.27.02.090.00	Washer	1
12	0.05.02.019.00	Roll pin 6x28 UNI 6873	1
13	1.23.00.041.00	Lever	1
14	0.99.00.132.00	Clamp with head screw art.1713	1
15	0.08.01.005.00	Seal 20x30x7	1
16	0.12.01.055.00	Screw plug 30x7	1
17	1.14.03.073.00	Shaft	1
18	0.07.03.001.00	Circlip RS15 UNI 7434	2
19	1.22.01.050.00	Fork	1
20	1.28.01.084.00	Coil spring	1
21	1.13.01.129.00	Shaft	1
22	1.17.02.069.00	Splined sleeve	1
23	1.14.01.048.00	Shaft	1
24	0.05.02.001.00	Roll pin 4x18 UNI 6873	1
25	0.01.01.027.00	Capscrew TE M6x20 UNI 5739 CL RES 8.8	1
26	1.99.00.181.00	Hose clamp	1
27	1.30.02.020.00	Hex nut	1
28	0.08.02.013.00	O-Ring OR 3100	2
29	1.21.02.033.00	Piston	1

REF.	CODE	DESCRIPTION	QT.
30	1.24.01.089.00	Cover	1
31	0.01.01.002.00	Capscrew TE M8x25 UNI 5739 CL RES 8.8	1
32	0.04.02.002.00	Lockwasher 8,4 UNI 1751	1
33	0.08.99.005.00	Gasket 1"	1
34	0.12.01.074.00	Retainer 1" Gas	1
35	0.08.01.001.00	Seal 25x52x8	1
36	1.01.02.141.00	Housing (PTO 3.2.79.9.5)	1
37	1.28.01.010.00	Coil spring CAC1/4	1
38	0.11.01.002.00	Ball 3/8"	1
39	1.14.03.085.00	Shaft	1
40	0.12.01.015.00	Plug	1
41	1.08.02.025.00	Cylinder	1
42	1.21.02.049.00	Piston	1
43	1.24.01.004.00	Cover mod4/2 G1/8	1
44	0.07.02.003.00	Circlip 49i UNI 7437	1
45	0.08.02.004.00	O-Ring OR 147	1
46	0.07.01.027.00	Circlip AS15x1,5 DIN 471	1
47	0.08.02.107.00	O-Ring OR 144 60° Shore	1
48	0.08.02.003.00	O-Ring OR 119	1
49	0.04.01.119.00	Washer 1"	1
50	0.08.02.100.00	O-Ring OR 123	1
51	0.08.02.014.00	O-Ring OR 3081	1
OPTIONAL: KIT SWITCH 2.05.437.0000			
52	0.04.01.065.00	Washer 8,4 DIN 433	1
53	0.01.01.029.00	Capscrew TE M8x10 UNI 5739 CL RES 8.8	1
54	0.99.00.226.00	Indicator switch	1
55	1.99.00.290.00	Bracket for switch	1
56	0.08.02.013.00	O-Ring OR 3100	1