

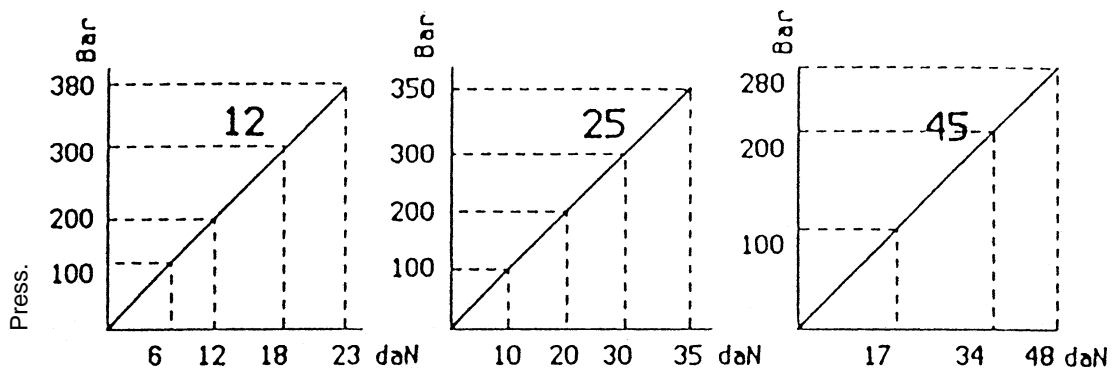

HAND PUMP WITH TWO POSITIONS TWO WAY CONTROL VALVE

4.1.9.4

CODE	DISPLACEMENT cm ³ / cycle	PRESSURE Max bar	WEIGHT Kg.
4.1.9.4.012.0.00	12	380	3,0
4.1.9.4.025.0.00	25	350	3,1
4.1.9.4.045.0.00	43	280	3,2

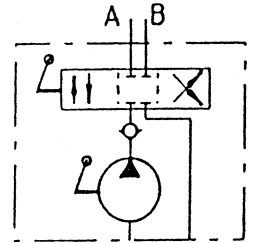

Working effort with 1 mt. hand lever

4.1.9.4.XXX.0.00

BASIC SERIAL NUMBER _____ DISPLACEMENT _____

GENERAL FEATURES

The hand pumps have specially been studied expressly for high performances and reliability; they are used in different sectors: transport, industry and agriculture.

The hand pumps can be installed both in horizontal and vertical position.

DIRECTIONS FOR USE.

- Oil** - Use only ISO 6743/4 (DIN 51524) hydraulic mineral oil
- Viscosity** - The viscosity must be according to ISO 3448 (DIN 51519) standards.
 Minimum viscosity: ISO VG 15
 Maximum viscosity: ISO VG 100
 Advised viscosity: ISO VG 46
- Filtration contamination** - The main cause of the bad working of hydraulic installations is the excessive fluid contamination.
 Advised filtration: 50 - 80 microns.
 Contamination class: 18/14 ISO 4406 (9 NAS 1638)
- Temperature** - Working temperature: from - 20° C to + 80° C

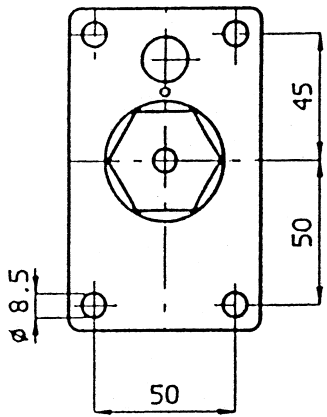

CODE	DIMENSIONS	
	A	B
4.1.9.4.012.0.00	141	257
4.1.9.4.025.0.00	141	257
4.1.9.4.045.0.00	163	272

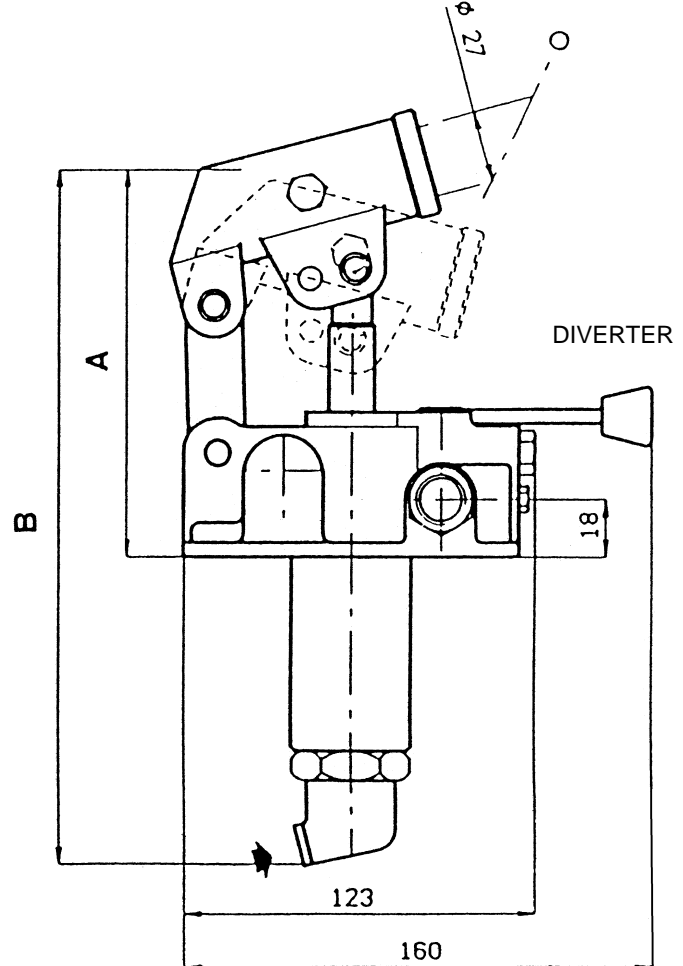
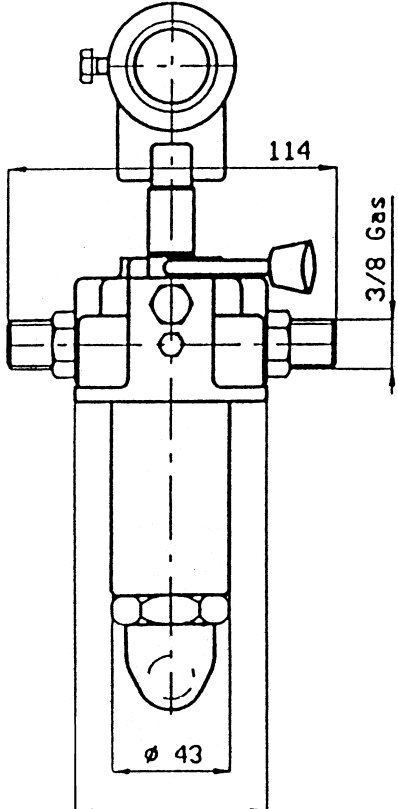

ON REQUEST: ROUN-DED TYPE LEVER COD. 2.99.034.0000
 RECTANGULAR TYPE LEVER COD. 2.99.201.0000

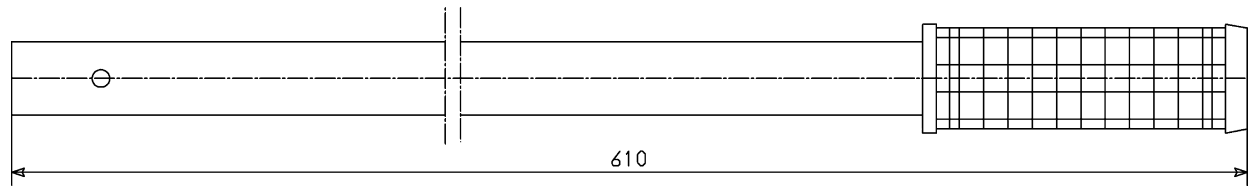

DIMENSIONS AND PART NUMBERS

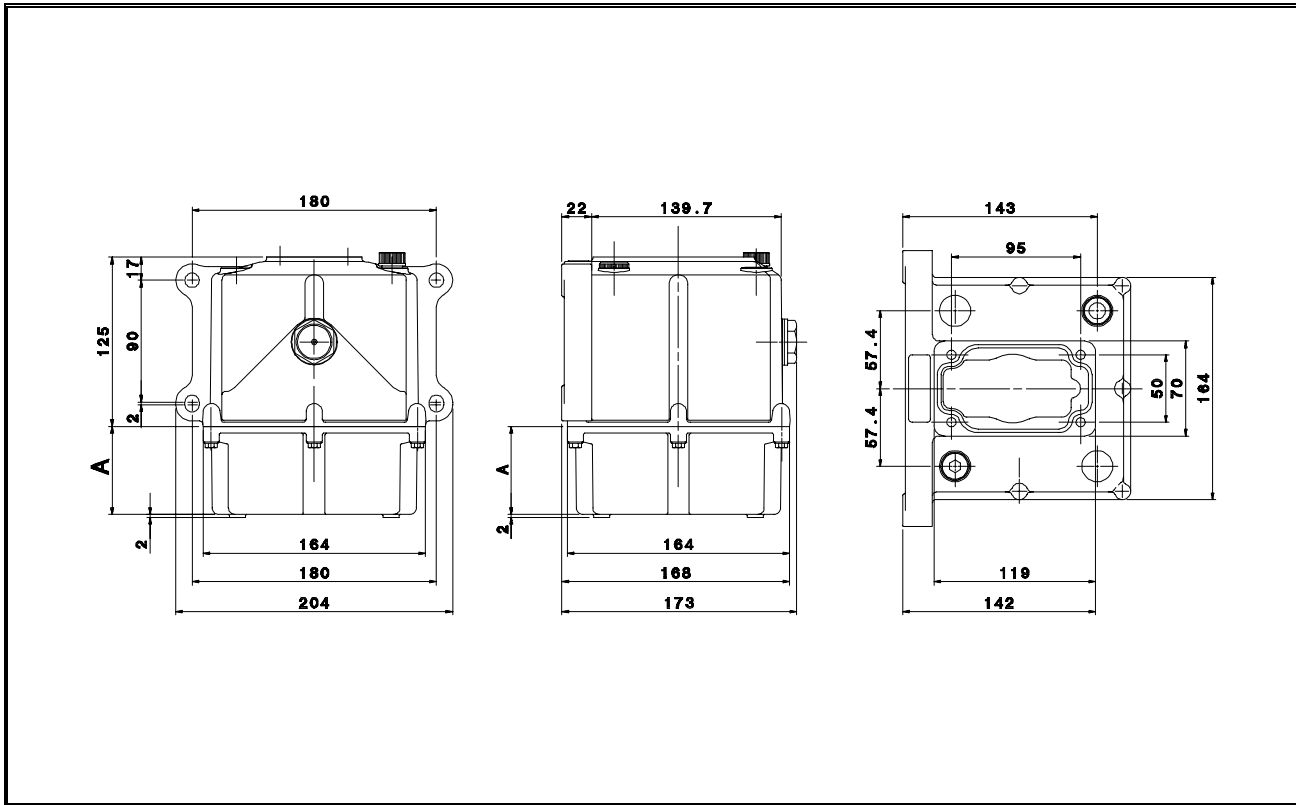

Picture 4 (tank dimensions)

Specifications and part numbers					
Part number	Description	"A" (mm)	Capacity (liter)	Oil readout	Weight (kg)
2.16.039.0000	Tank 02 lt PMP.MNO.	25	02	No	1,5
2.16.040.0000	Tank 02 lt PMP.MNO. with oil level readout			Yes	
2.16.041.0000	Tank 03 lt PMP.MNO.	70	03	No	1,6
2.16.042.0000	Tank 03 lt PMP.MNO. with oil level readout			Yes	
2.16.043.0000	Tank 05 lt PMP.MNO.	180	05	No	1,8
2.16.044.0000	Tank 05 lt PMP.MNO. with oil level readout			Yes	

Table 2 (Tank specifications and part numbers)

WARNING

Current Edition 28/07/2002 of our catalogue is replacing any previous document.

Dimensions and other specifications contained in this catalogue are suitable of modification at our discretion without previous notice. Drawings contained in this catalogue are subject to copyright. Always mention our ordering codes or part numbers. General sales conditions are specified in our currently valid price list.