

## DP 25 OPEN-CENTER TIPPING VALVE WITH DUAL SETTING

# 3.3.1.045.

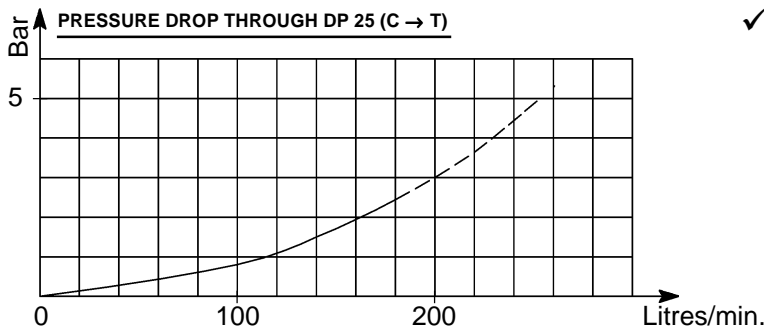

- ✓ **Air operated, open center valve** for raising and lowering the tipping body.
- ✓ Used with **3.3.2.021.18** or **3.3.2.022.21** air controls it features proportional descent speed and complies with the safety requirements of the **CE Machinery Directive**.
- ✓ **The built-in pressure relief valve protects the tipping cylinder** from pressure shocks when in the hold position.
- ✓ **Pressure check port** for monitoring system pressure.
- ✓ For systems working with **two different relief pressure settings**.
- ✓ Option available for use with **an external secondary pressure relief valve** for three pressure settings.
- ✓ Suitable for both tank or chassis mounting.



Three way (pump, cylinder, tank) air operated control valve. Three positions:

- Hold.
- Tipping.
- Lowering.

Three modes of descent:

- One speed only.
- Two speeds (fast and slow).
- Variable descent speed with suitable air control.

Relief valve setting up to 350 Bar.

Built-in check valve.

Air pressure 4,5 - 12 Bar.

Flow up to 180 litres/min.

WEIGHT: kg. 8

**3.3.1.045.XX.XX**

BASIC SERIAL NUMBER

VERSIONS

**30** = VALVE WITH DUAL SETTING

**31** = OPTION FOR THIRD PRESSURE SETTING

RELIEF VALVE PRESSURE SETTING

**14** = 140/220 Bar

**15** = 150/250 Bar

**22** = 220/350 Bar

**CODE 3.3.1.045.30.XX DUAL SETTING VALVE**

**CODE 3.3.1.045.31.XX DUAL SETTING VALVE FOR USE WITH EXTERNAL THIRD PRESSURE RELIEF VALVE PART No. 2.15.014.00.XX**

**ATTENTION**  
Mount on a flat surface and tighten the three M8 bolts to 2 kgm torque.

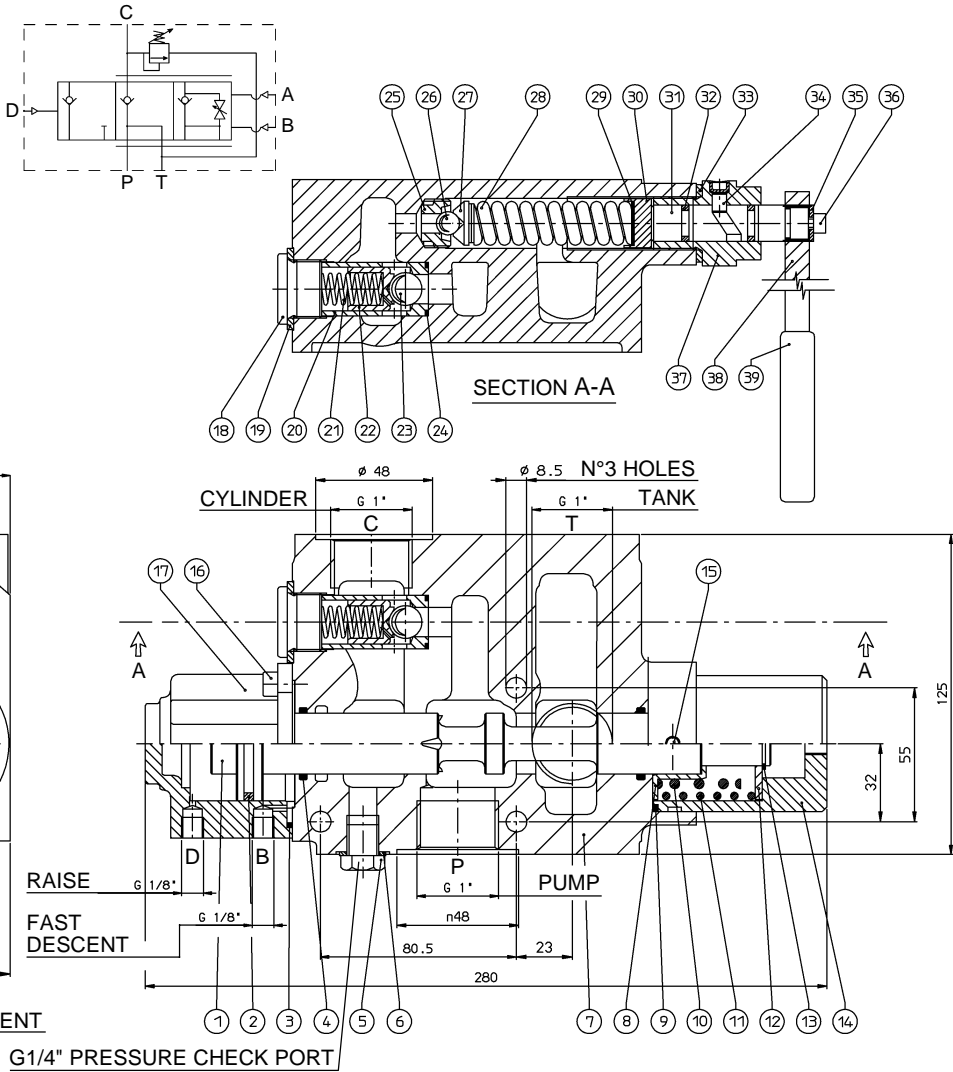
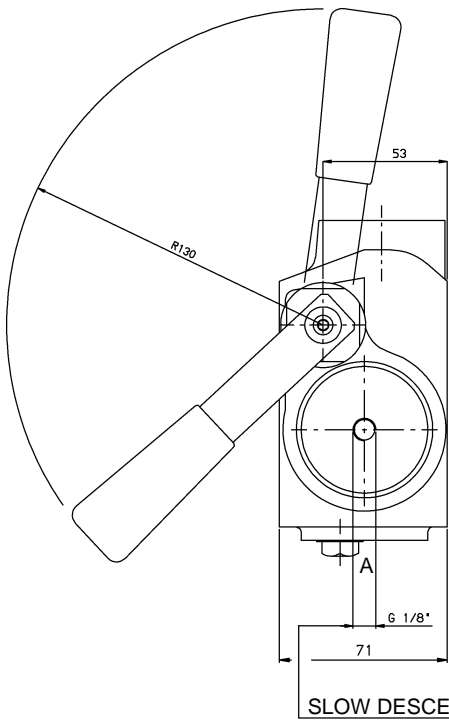

REF.	CODE	DESCRIPTION	QT.
1	1.15.00.061.00	Valve spool	1
2	0.08.02.107.00	O-Ring OR 144 60° Shore	1
3	0.08.02.048.00	O-Ring OR 3218	1
4	0.08.02.099.00	O-Ring OR 3100	2
5	1.30.03.029.00	Plug G1/4"	1
6	0.04.01.077.00	Washer 13,5x19x1,5	1
7	1.06.01.023.00	DP 25 Valve body	1
8	1.27.02.108.00	Spring cap	1
9	0.08.02.047.00	O-Ring OR 3200	1
10	1.28.01.110.00	Coil spring	1
11	1.28.01.099.00	Coil spring	1
12	1.27.02.107.00	Washer 18x46x3	1
13	0.07.01.015.00	Circlip 18e UNI 7435	1
14	1.24.99.010.00	Spring cover	1
15	0.01.05.014.00	Capscrew STEI M6x6 UNI 5923 CL RES 45H	2
16	0.01.03.001.00	Capscrew TCEI M6x14 UNI 5931 CL RES 8.8	4
17	1.08.01.016.00	Cylinder	1
18	0.12.01.051.00	Plug M24x1,5 DIN 908	1
19	0.04.01.087.00	Washer 24,3x33,3x2,5	1
20	1.25.02.050.00	Bushing	1
21	1.28.01.056.00	Coil spring	1
22	1.99.00.224.00	Shutter	1
23	0.11.01.012.00	Ball 17/32"	1
24	0.08.02.070.00	O-Ring OR 2075	1
25	1.25.02.058.00	DP 25 Valve seat	1
26	0.11.01.002.00	Ball 3/8"	1

REF.	CODE	DESCRIPTION	QT.
27	1.27.02.157.00	Ball cap	1
28	1.28.01.102.00	Coil spring (for DP 140/220 and 150/250 bar)	1
	1.28.01.083.00	Coil spring (for DP 220/350 bar)	1
29	1.99.00.235.00	Disc	5
30	1.26.01.118.00	Spring cap	1
	1.14.02.038.00	Pivot rod (for DP 140/220 bar)	1
31	1.14.02.039.00	Pivot rod (for DP 220/350 bar)	1
	1.14.02.042.00	Pivot rod (for DP 150/250 bar)	1
32	0.08.02.040.00	O-Ring OR 112	2
33	0.04.01.088.00	Washer 23,5x31,8x2,5	1
34	0.11.02.002.00	Roller 6x8	1
35	0.04.01.117.00	Washer 5,5x15x1,6 UNI 6593	1
36	0.01.03.012.00	Capscrew TCEI M5x12 UNI 5931 CL RES 8.8	1
37	1.08.01.016.00	Cylinder	1
38	1.23.00.045.00	Lever	1
39	0.99.00.165.00	Black handle 1009-20x8	1
<b>FOR VALVE PART No. 3.3.1.045.31 ONLY</b>			
7	1.06.01.035.00	DP 25 Valve body	1
	0.04.01.010.00	Washer 10x16x1,5	1
	0.12.01.059.00	Plug U-908G1/8	1

## CODE 2.05.322.0000 TANK MOUNTING PLATE

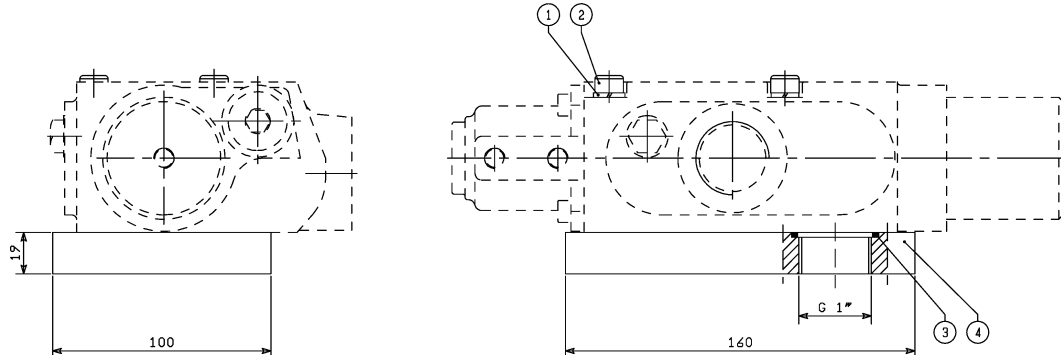

REF.	CODE	DESCRIPTION	QT.
1	0.04.02.002.00	Lockwasher 8,4 UNI 1751	3
2	0.01.03.064.00	Capscrew TCEI M8x75 UNI 5931 CL RES 8.8	3
3	0.08.02.024.00	O-Ring OR 3137	1
4	1.10.02.046.00	Base plate	1

## CODE 2.15.014.00.XX SECONDARY PRESSURE RELIEF VALVE

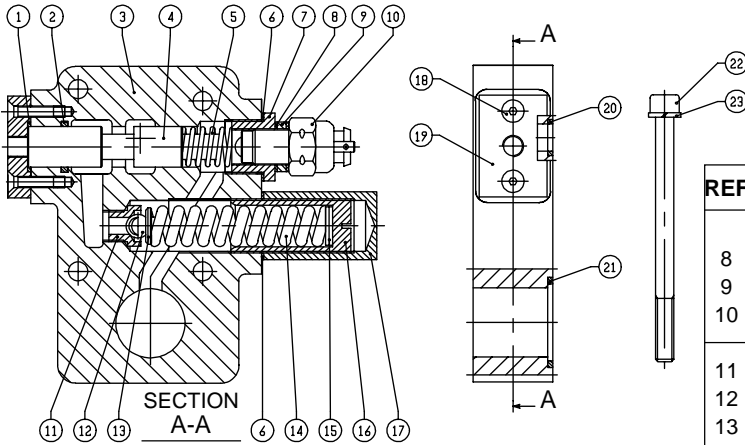

REF.	CODE	DESCRIPTION	QT.
1	0.08.02.070.00	O-Ring OR 2075	1
2	0.08.02.057.00	O-Ring OR 123	1
3	1.06.99.030.00	DP25 Valve body	1
4	1.15.00.053.00	Valve spool	1
5	1.28.01.089.00	Coil spring	1
6	1.27.02.055.00	Washer 30x24x1,5	2
7	1.30.03.037.00	Plug	1

REF.	CODE	DESCRIPTION	QT.
<b>PARTS INCLUDED IN KIT No. 2.99.122.0000</b>			
8	0.04.01.003.00	Washer 16x22x1	2
9	1.26.01.096.00	Spacer	1
10	0.99.00.067.00	(El.)Switch	1
11	1.25.02.043.00	Valve seat	1
12	0.11.01.003.00	Ball 13/32"	1
13	1.27.02.015.00	Cover mod63/2	1
14	1.28.01.102.00	Coil spring	1
15	0.04.01.070.00	Washer 8x17x1,6	2
16	1.30.01.055.00	Setting screw	1
17	1.30.03.036.00	Cap	1
18	0.01.04.008.00	Capscrew TSPEI M5x20 UNI 5933 CL RES 10,9	2
19	1.24.02.033.00	Cover	1
20	0.08.02.065.00	O-Ring OR 3043	1
21	0.08.02.024.00	O-Ring OR 3137	2
22	0.01.03.088.00	Capscrew TCEI M8x110 UNI 5931	3
23	0.04.02.002.00	Lockwasher 8,4 UNI 1751	3

## AIR SYSTEM WITH OPEN-CENTER TIPPING VALVE AND THREE-WAY PROPORTIONAL CAB CONTROL

