

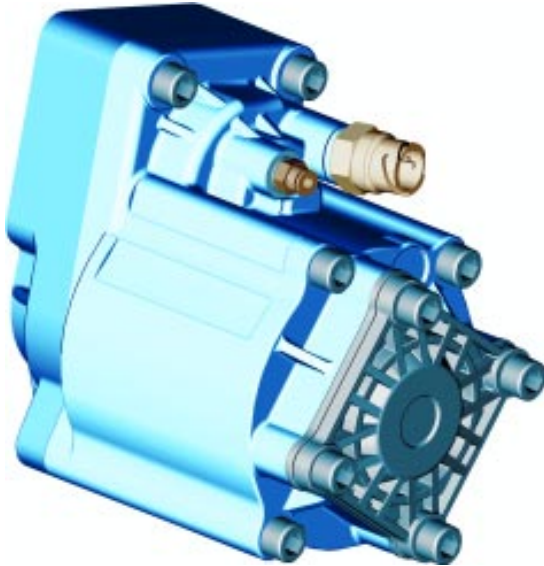

## POWER TAKE-OFF 4.2.07.



- Power take-off with two air inlets for 6 mm diam. tube; one inlet controls the engagement of the PTO splined sleeve and the other one controls the engagement of the clutch on the output axle.
- Maximum transmissible dynamic torque (i.E. engagement under rotation):  
300 Nm at max. 1000 r.p.m. output speed.
- Maximum transmissible static torque (i.E. with clutch already engaged):  
for PTO ratio 1,80 - 350 Nm,  
for PTO ratio 1,57 - 400 Nm,  
for PTO ratio 1,33 - 450 Nm.
-  Minimum air pressure to engage the clutch: 8 Bar.
- PTO provided with threaded hole for the forced oil lubrication in those gearboxes, which require it.
- For all heavy-duty applications, the relevant lube kits are required.

Technical data: refer to the transmission application manual.

**OUTPUT TORQUE:**

see different types available.

### 4.2.07.XX.00.X.X

BASIC SERIAL NUMBER

GEARBOX TYPE

- 01** = \*ZF ECOSPLIT - ZF AS-TRONIC - EATON TWINSPLITTER - VOLVO R70, 1000, 1400, 1700 - SR70, 1400, 1700, 1900, 2000 - SRO2400 - \*\*VOLVO VT
- 02** = ZF 5-35, 6-36, 6S850 - EATON 4106, 5109, 6109 - EATON RTS/RTSO 12316A, 17316A - \*\*\*IVECO 2895.9
- 05** = MERCEDES G/GV4 - G125, 135, 155, 180
- 13** = NEW MERCEDES ACTROS - AXOR FROM G210 TO G260
- 14** = MERCEDES G100
- 17** = MERCEDES G56-6

VERSION

- 1** = OUTPUT 350 Nm - INTERNAL SPEED RATIO 1.800
- 2** = OUTPUT 400 Nm - INTERNAL SPEED RATIO 1.578
- 3** = OUTPUT 450 Nm - INTERNAL SPEED RATIO 1.333

SPECIAL OPTIONS

- 0** = STANDARD
- 9** = VERSION WITH THE CONNECTION ENGAGED GEARBOX

### OUTPUT SHAFT OPTION

#### DESCRIPTION

Direct mounting PZB pumps-3 bolt mtg. flange (see chart Y type M)	<b>KIT 2.05.324.0000</b>
For remote transmission SPICER 1300/DIN 10 (see chart X group E)	<b>KIT 2.05.323.0000</b>
For remote transmission SPICER 1120/DIN 00 (see chart X group E)	<b>KIT 2.05.330.0000</b>
Direct mounting ISO 4 bolt mtg. flange pumps (see chart Y type H)	<b>KIT 2.05.087.0000</b>

- \* Use lubrication kit code 2.99.154.0000 (only for ZF ECOSPLIT gearbox)
  - \*\* Use lubrication kit code 2.99.155.0000 (only for VOLVO VT gearbox)
  - \*\*\* Use lubrication kit code 2.99.153.0000 (only for IVECO 2895.9 gearbox)
- On request, a lubrication kit is available for fitment on all other gearboxes.*

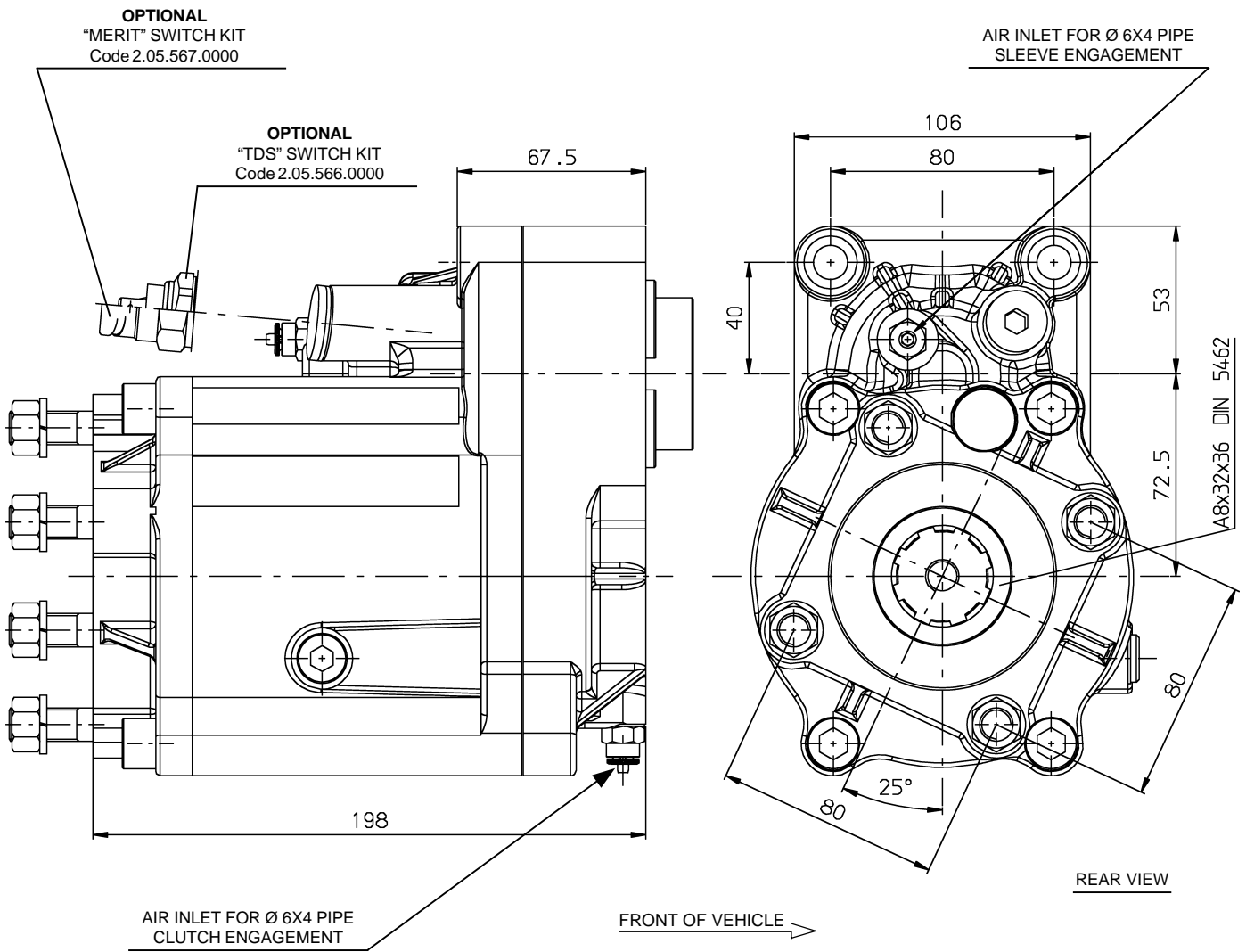

**THE SHOWN ADAPTORS ARE SUPPLIED WITH THE PTO,  
ACCORDING TO THE GEARBOX MODEL**

**MERCEDES G/GV4 - G125,135,155,180**

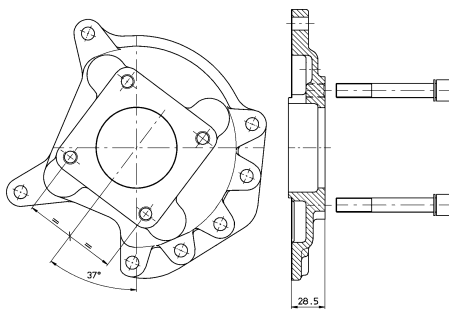

**NEW MERCEDES ACTROS - AXOR  
FROM G 210 TO G260**

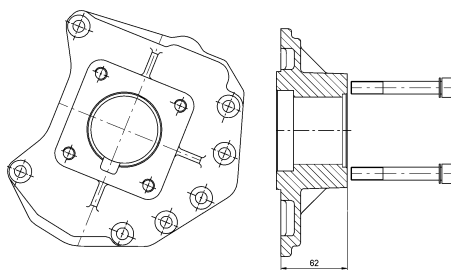

**MERCEDES G100**

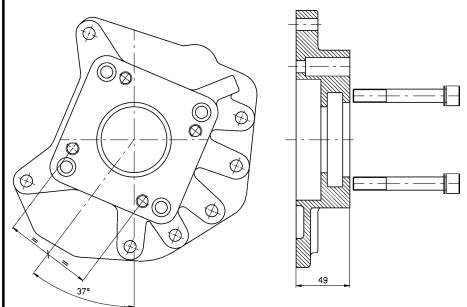

**MERCEDES G56-6**

