



Technical data: refer to the transmission application manual.

OUTPUT TORQUE:

30 kgm. (if allowed from the gearbox).

WEIGHT: kg. 8

4.2.02.XX.XX.0.0

BASIC SERIAL NUMBER _____ OUTPUT SHAFT OPTION _____

GEARBOX TYPE _____

- 01** = ZF 4-120, 4-150 - FROM 5-50 TO 16-251 - AS-TRONIC - EATON TWINSPLITTER - VOLVO R70, 1000, 1400, 1700 - SR70, 1400, 1700, 1900, 2000 - SRO2400 - VT
- 02** = ZF 5-35, 6-36, 6S850 - EATON 4106, 5109, 6109 - RTS/RTSO 12316A, 17316A
- 03** = MERCEDES G3/36, 40, 45, 50, 55, 60, 61
- 05** = MERCEDES G/GV4
- 06** = VOLVO R51 - R/SR52
- 07** = VOLVO R/MR/SR61, 62 - MR62B
- 09** = MAN-VOLKSWAGEN 007.1
- 11** = TATRA
- 12** = MERCEDES G60, 85
- 13** = MERCEDES G125, 135, 155, 180, 200, 210, 211, 240, 260
- 14** = MERCEDES G100
- 16** = MERCEDES EURO 2
- 17** = MERCEDES G56-6

OUTPUT SHAFT OPTION

DESCRIPTION	CODE
For remote transmission (see chart X group A)	04
3 bolt output PTO for direct PZB pump mounting (see chart Y type A)	04
ISO pump mounting to bearing supported PTO output (with bearing)	05
Flange mounting to bearing supported PTO output (see chart X group E)	06
ISO 4 bolt PTO output	12

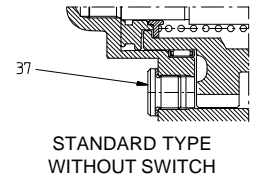
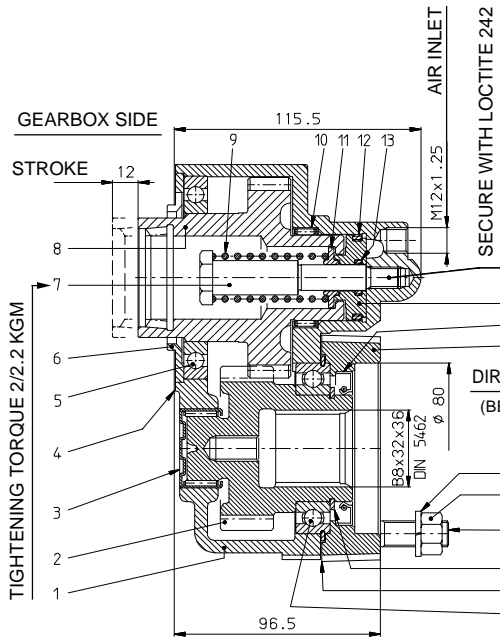
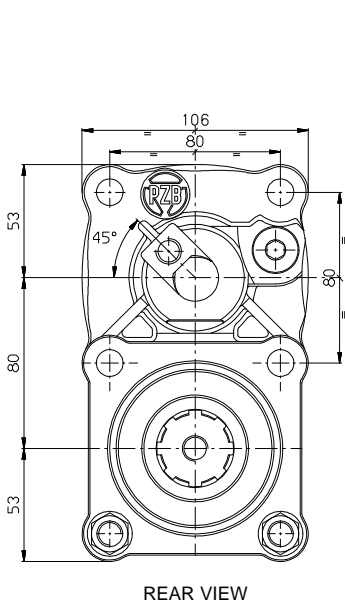

DETAIL OF SWITCH KIT

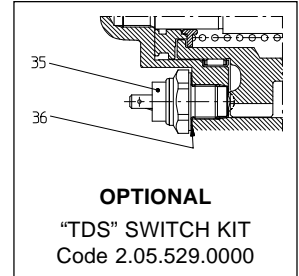

**DIRECT ISO/SE OUTPUT
(BEARING SUPPORTED
OUTPUT)
TYPE "05"**

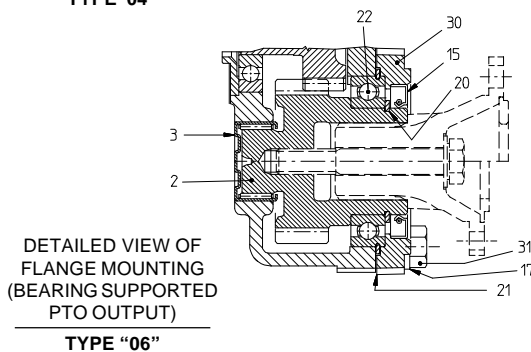
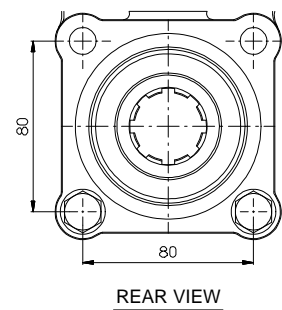
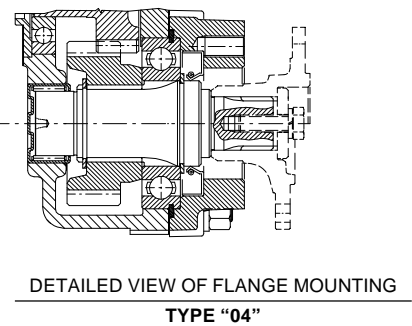
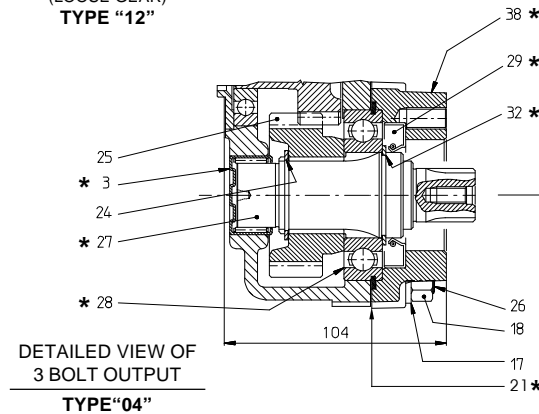
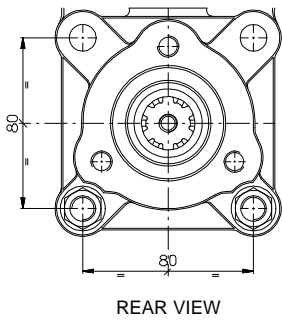
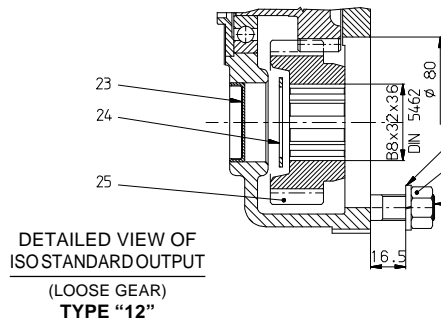
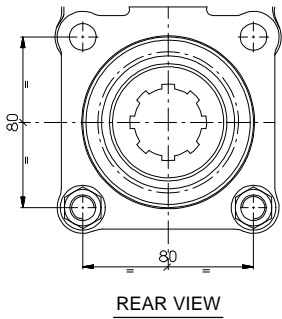
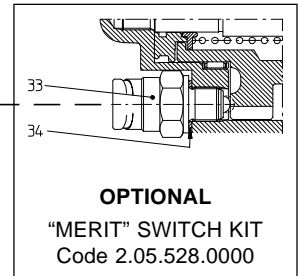
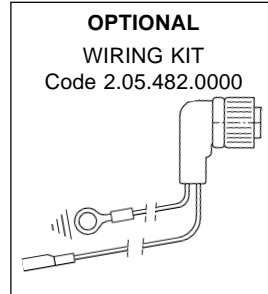

TYPE "04"
Components marked with *
can be supplied as
kit 3.5.2.023.0000

THE DRAWING SHOWS: 4.2.02.01 (ISO A) FOR GEARBOXES ZF 4-120, 4-150 - FROM 5-50 TO 16-251 - AS-TRONIC - EATON TWINSPLITTER

4.2.02.02 (ISO B) FOR GEARBOXES ZF 5-35, 6-36, 6S850 - EATON 4106, 5109, 6109 - RTS/RTSO 12316A, 17316A - VOLVO R70, 1000, 1400, 1700 - SR70, 1400, 1700, 1900, 2000 - SRO2400

REF.	CODE	DESCRIPTION	QT.
1	1.01.02.142.00	Housing	1
2	1.11.10.153.00	Gear 22 T	1
3*	0.10.07.001.00	Needle cage DBK 30/20	1
4	1.29.01.014.00	Gasket PTO/gearbox	1
5	0.10.01.033.00	Bearing 16012	1
6	1.27.02.010.00	Centering ring 303/6	1
7	1.30.01.088.00	Capscrew	1
	1.11.10.039.00	Gear 29 T (PTO 4.2.02.01)	
	1.11.10.042.00	Gear 29 T (PTO 4.2.02.02)	
	1.11.10.151.00	Gear 29 T (PTO 4.2.02.03/17)	
	1.11.10.041.00	Gear 29 T (PTO 4.2.02.05)	
	1.11.10.044.00	Gear 29 T (PTO 4.2.02.06)	
8	1.11.10.043.00	Gear 29 T (PTO 4.2.02.07)	1
	1.11.10.045.00	Gear 29 T (PTO 4.2.02.09)	
	1.11.10.110.00	Gear 29 T (PTO 4.2.02.11)	
	1.11.10.152.00	Gear 29 T (PTO 4.2.02.12)	
	1.11.10.150.00	Gear 29 T (PTO 4.2.02.13/16)	
	1.11.10.041.00	Gear 29 T (PTO 4.2.02.14)	
9	1.28.01.007.00	Coil spring 408A/9	1
10	0.10.07.005.00	Needle cage HK4012	1
11	1.27.02.125.00	Ring	1
12	0.08.02.012.00	O-Ring OR 4131	1
13	0.08.02.002.00	O-Ring OR 115	1
14	1.21.02.040.00	Piston	1
15	0.08.01.067.00	Seal 50x72x8	1
16	1.07.01.180.00	Flange	1
17	0.04.02.004.00	Lockwasher 13 UNI 1751	2
18	0.03.01.019.00	Hex nut M12 ch. 17	2
19	0.02.02.057.00	Stud M12x60 UNI 5911	2
20	0.07.01.013.00	Circlip 50e UNI 7435	1
21*	1.29.01.013.00	Gasket 735A/6	1
22	0.10.01.052.00	Bearing 6010NR	1
23	0.12.01.040.00	Plug 37x5	1
24	0.07.01.003.00	Circlip 35e UNI 7435	1
25	1.11.03.095.00	Gear 22 T	1
26	0.02.02.031.00	Stud M12x30 UNI 5911	2
27*	1.13.01.125.00	Shaft	1
28*	0.10.01.005.00	Bearing 6208-NR	1
29*	0.08.01.070.00	Seal 40x68x10	1
30	1.07.01.181.00	Flange	1
31	0.01.01.024.00	Capscrew TE M12x35 UNI 5739 CL RES 8.8	2
32*	0.07.01.002.00	Circlip 40e UNI 7435	1
OPTIONAL: "MERIT" SWITCH KIT CODE 2.05.528.0000			
33	0.99.00.290.00	Switch MERIT	1
34	0.04.01.136.00	Washer 16x27x1,5	1
OPTIONAL: "TDS" SWITCH KIT CODE 2.05.529.0000			
35	0.99.00.291.00	Switch TDS	1
36	0.04.01.151.00	Washer 16x27x0,5	1
37	0.12.01.104.00	Oil plug with gasket TCNB 16.15	1
38*	1.07.01.007.00	Flange for 3-bolt pump on ISO PTO AS10/11	1

**THE SHOWN ADAPTORS ARE SUPPLIED WITH THE PTO,
ACCORDING TO THE GEARBOX MODEL**

MERCEDES G3/36, 40, 45, 50, 55, 60, 61

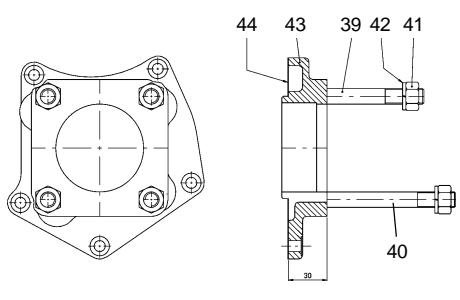

MERCEDES G/GV4

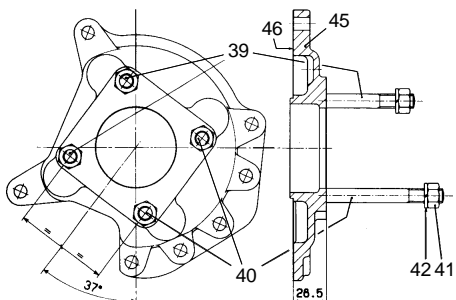

VOLVO R51 - R/SR52

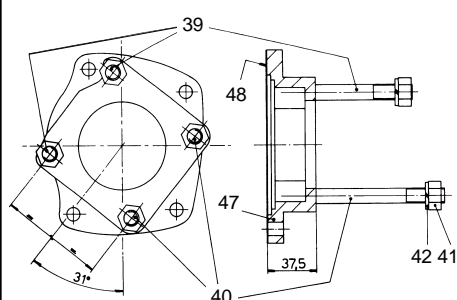

VOLVO R/MR/SR61, 62 - MR62B

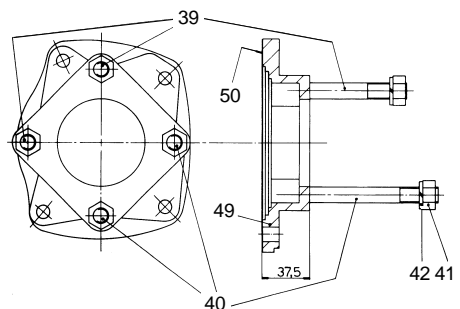

MAN-VOLKSWAGEN 007.1

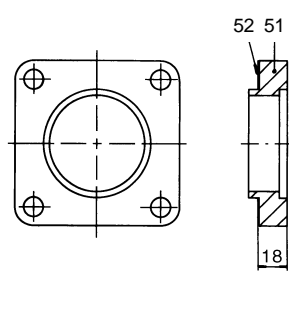

TATRA

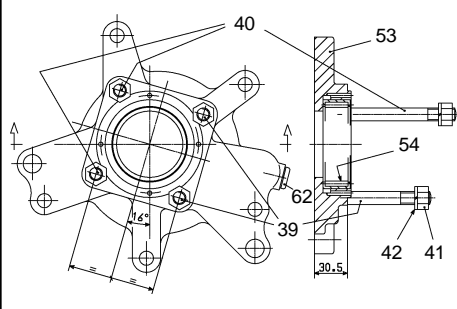

MERCEDES G60, 85

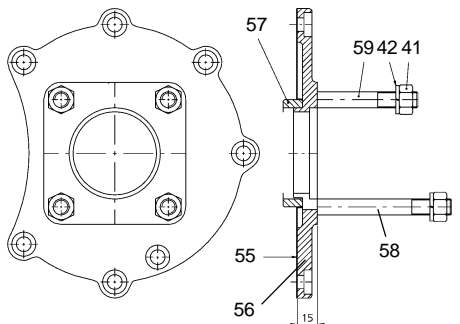

MERCEDES G125, 135, 155, 180, 200, 210, 240, 260

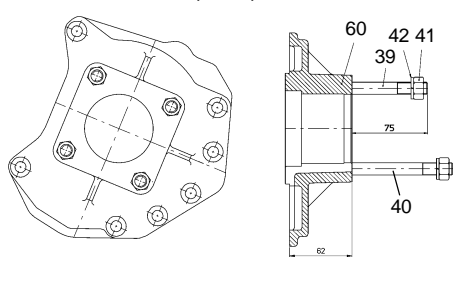

MERCEDES G100

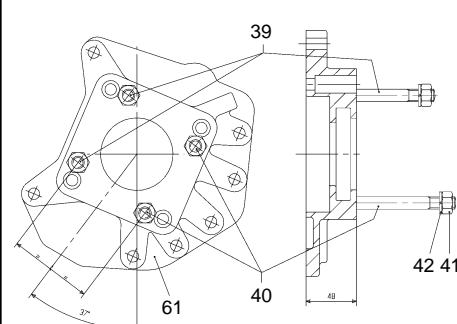

MERCEDES EURO 2

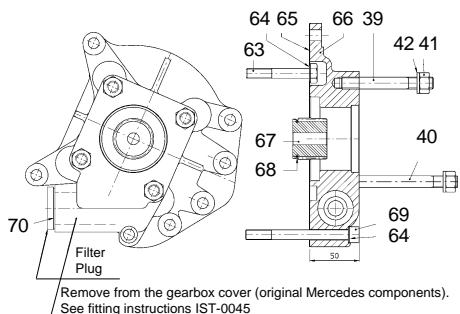

MERCEDES G56-6

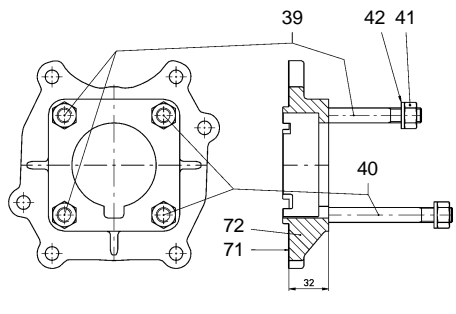

REF.	CODE	DESCRIPTION	QT.
39	0.02.02.006.00	Stud M12x75 UNI 5911	2
40	0.02.02.045.00	Stud M12x100 UNI 5911	2
	0.02.02.009.00	Stud M12x125 UNI 5911 (type "05")	
41	0.03.01.019.00	Hex nut M12 ch. 17	4
42	0.04.02.004.00	Lockwasher 13 UNI 1751	4
44	1.29.01.132.00	Gasket PTO/gearbox	1
45	1.07.01.117.00	Adapter Mercedes G125-155-180 g.box	1
46	1.29.01.119.00	Gasket PTO/gearbox	1
47	1.07.01.013.00	Adapter Volvo R5 gearbox	1
48	1.29.01.046.00	Gasket PTO/gearbox	1
49	1.07.01.008.00	Adapter Volvo R6 g.box/pto ISO 749A/1	1
50	1.29.01.017.00	Gasket PTO/gearbox	1
51	1.07.01.040.00	Filler block ISO 4-bolt thickness 17,5	1
52	1.29.01.014.00	Gasket PTO/gearbox	1
53	1.07.01.148.00	Adapter Tatra gearbox	1
54	0.10.08.007.00	Needle cage NK 68/25 A	1
55	1.29.01.133.00	Gasket PTO/gearbox	1

REF.	CODE	DESCRIPTION	QT.
56	1.07.01.187.00	Adapter Mercedes G60-G 85 gearbox	1
57	1.27.02.153.00	Centering ring	1
58	0.02.01.014.00	Stud M12x100 UNI 5909	2
	0.02.01.015.00	Stud M12x125 UNI 5909 (type "05")	
59	0.02.01.013.00	Stud M12x75 UNI 5909	2
60	1.07.01.184.00	Adapter Mercedes G125-135-155 g.box	1
61	1.07.01.173.00	Adapter Mercedes G100 gearbox	1
62	0.12.01.061.00	Oil plug with gasket TCNB 1415	1
63	0.01.01.096.00	Capscrew TE M10x65 UNI	4
64	0.04.04.001.00	Washer Schnorr 1	5
65	1.29.01.137.00	Gasket PTO/gearbox	1
66	1.07.01.195.00	Adapter Mercedes Euro 2 gearbox	1
67	1.17.03.022.00	Splined sleeve	1
68	1.99.00.331.00	Circlip	1
69	0.01.03.100.00	Capscrew TCEI M10x105	1
70	0.04.01.161.00	Washer 38.5	1
71	1.29.01.510.00	Gasket PTO/gearbox	1
72	1.07.01.518.00	Adapter Mercedes G56-6 gearbox	1