



POWER TAKE-OFF 3.2.97.1.

FOR GEARBOX :
MITSUBISHI M015S5

POWER TAKE-OFF 3.2.97.2.

FOR GEARBOX :
MITSUBISHI M025S5

POWER TAKE-OFF 3.2.97.3.

FOR GEARBOX :
MITSUBISHI M035S5

Technical data: refer to transmission application manual.

OUTPUT TORQUE:

15 kgm. (increase of 50% for intermittent service).

WEIGHT: kg. 3

3.2.97.X.X.XX.0.X

BASIC SERIAL NUMBER

GEARBOX TYPE

- 1** = M015S5
- 2** = M025S5
- 3** = M035S5

VERSION

- 1** = PNEUMATIC CONTROL
- 2** = MECHANICAL "TC" CONTROL
- 3** = MECHANICAL "PUSH-PULL" CONTROL
- 4** = ELECTRIC CONTROL
- 5** = VACUUM CONTROL

COMPANION FLANGE FOR REMOTE TRANSMISSION

0 = NO OPTION

1 = SPICER 1120 CODE 2.05.054.0000

3 = DIN 00 CODE 2.05.056.0000

OUTPUT SHAFT OPTION

OUTPUT SHAFT OPTION

DESCRIPTION	CODE
For remote transmission (see chart X group A)	02
Direct mounting PZB pumps-3 bolt mtg. flange (see chart Y type A)	04
Direct mounting ISO 4 bolt mtg. flange pumps (see chart Y type P)	04

PNEUMATIC CONTROL

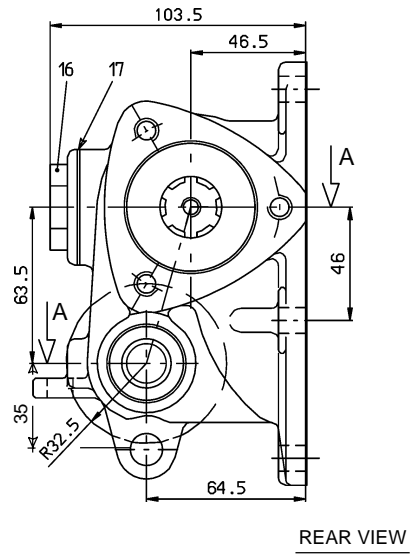
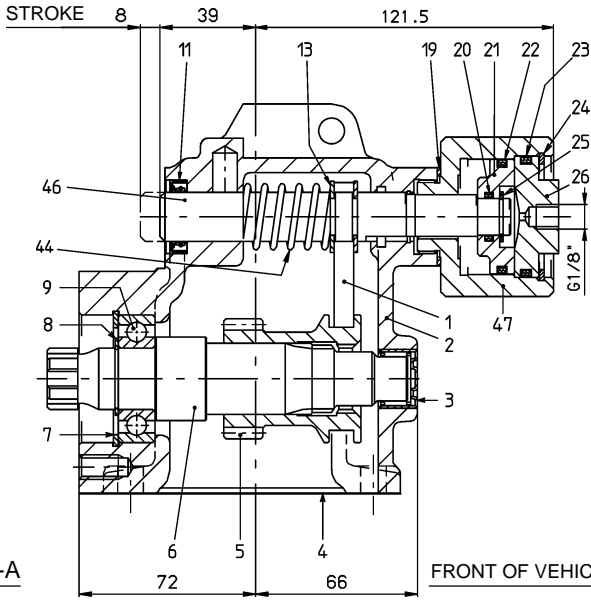

MECHANICAL "TC" CONTROL

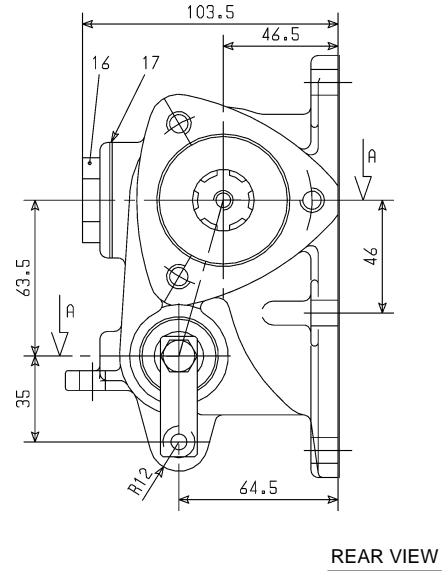
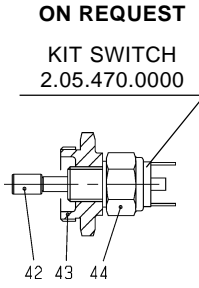
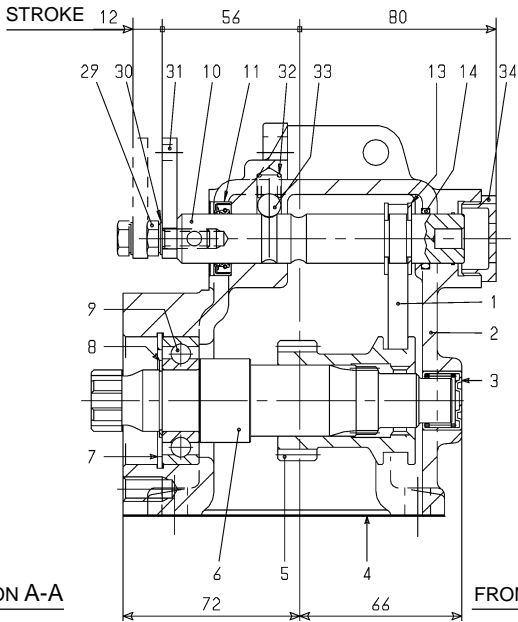

MECHANICAL "PUSH-PULL" CONTROL

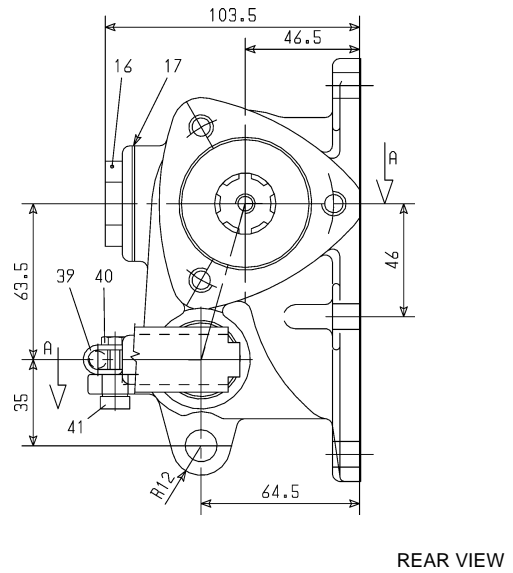
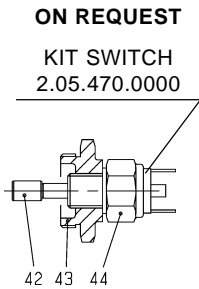
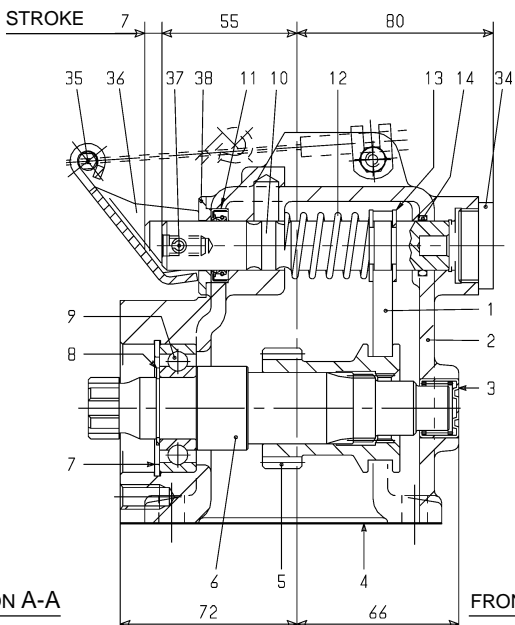

ELECTRIC CONTROL

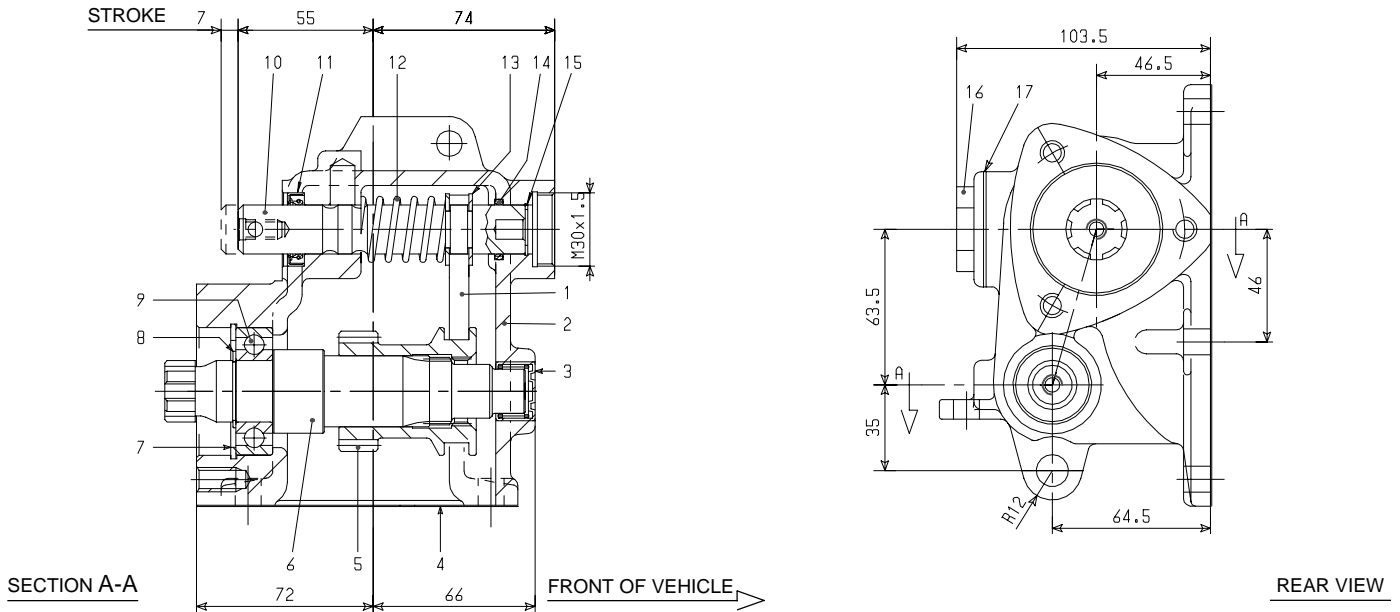

VACUUM CONTROL

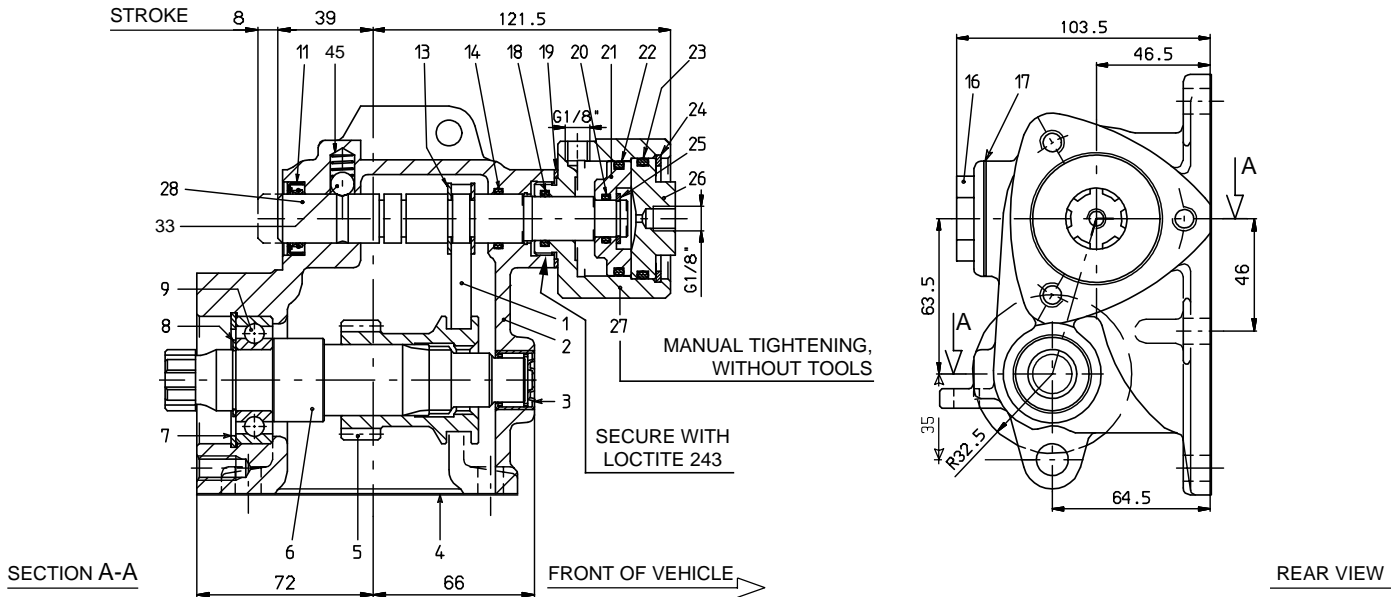

REF.	CODE	DESCRIPTION	QT.	REF.	CODE	DESCRIPTION	QT.
1	1.22.01.041.00	Fork	1	24	0.07.02.003.00	Circlip 49i UNI 7437	1
2	1.01.01.033.00	Housing	1	25	0.07.01.027.00	Circlip AS15x1,5 DIN 471	1
3	0.10.07.013.00	Needle cage BK18/16	1	26	1.24.01.004.00	Cover mod4/2 G1/8	1
4	1.29.01.088.00	Gasket PTO/gearbox	1	27	1.08.02.025.00	Cylinder	1
	1.11.07.155.00	Gear 16 T (PTO 3.2.97.1)		28	1.14.03.085.00	Shaft	1
5	1.11.07.156.00	Gear 16 T (PTO 3.2.97.2)	1	29	0.01.01.001.00	Screw TE M8x20 UNI 5739 CL RES 8.8	1
	1.11.07.154.00	Gear 15 T (PTO 3.2.97.3)		30	0.04.04.003.00	Washer Schnorr 8	1
6	1.13.01.166.00	Shaft	1	31	1.00.08.038.00	Extention	1
7	0.07.02.004.00	Circlip 52i UNI 7437	1	32	1.28.01.003.00	Coil spring mod.15/2	1
8	0.07.01.005.00	Circlip 25e UNI 7435	1	33	0.11.01.002.00	Ball 3/8"	1
9	0.10.01.001.00	Bearing 6205	1	34	0.12.01.100.00	Plug M30	1
10	1.14.03.087.00	Shaft	1	35	0.99.00.132.00	Clamp with head screw art.1713	1
11	0.08.01.005.00	Seal 20x30x7	1	36	1.23.00.041.00	Lever	1
12	1.28.01.084.00	Coil spring	1	37	0.05.02.019.00	Roll pin 6x28 UNI 6873	1
13	0.07.03.001.00	Circlip RS15 UNI 7434	2	38	1.27.02.090.00	Washer	1
14	0.08.02.014.00	O-Ring OR 3081	1	39	1.99.00.181.00	Hose clamp	1
15	0.07.02.049.00	Circlip 20i UNI 7437	1	40	0.01.01.027.00	Screw TE M6x20 UNI 5739 CL RES 8.8	1
16	0.12.01.074.00	Retainer 1" Gas	1	41	1.30.02.020.00	Hex nut	1
17	0.08.99.005.00	Gasket 1"	1	ON REQUEST: KIT SWITCH 2.05.470.0000			
18	0.08.02.100.00	O-Ring OR 123	1	42	0.11.02.001.00	Dowel 8x12	1
19	0.04.01.119.00	Washer 1"	1	43	1.30.03.056.00	Cover	1
20	0.08.02.003.00	O-Ring OR 119	1	44	0.99.00.226.00	Indicator switch	1
21	1.21.02.049.00	Piston	1	45	1.28.01.010.00	Coil spring	1
22	0.08.02.107.00	O-Ring OR 144 60° Shore	1	46	1.14.03.09400	Shaft	1
23	0.08.02.004.00	O-Ring OR 147	1	47	1.08.02.027.00	Cylinder	1