

# CLUTCH POWER TAKE OFF CS12

## ALLISON WORLD HEAVY DUTY

### MODEL NUMBER CONSTRUCTION

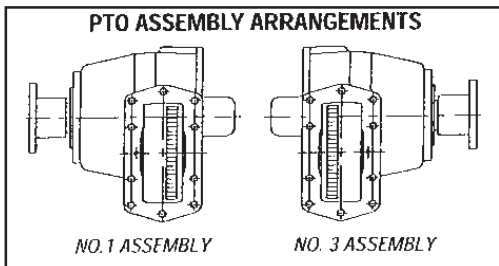
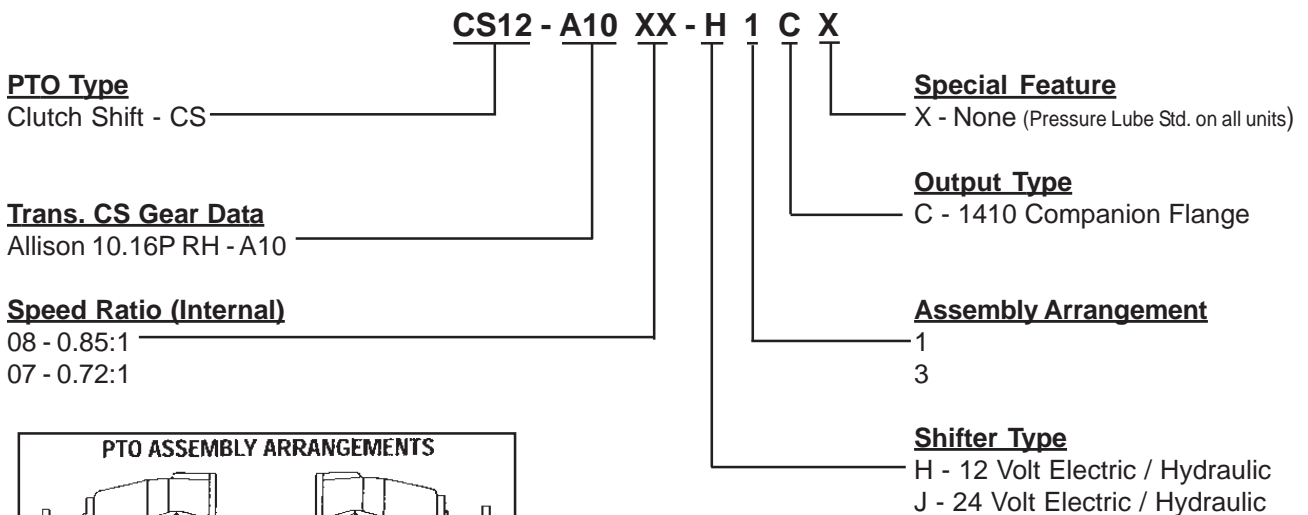

### CLUTCH HUB REPLACEMENT

Effective April 1999 the clutch hub supplied in the CS10 Series PTO has the two piece clutch hub as shown on this page. The two piece hub consists of a splined hub and a flange which is held together by a snap ring. Because of this design change the clutch pack stack up has changed as shown on Page 3.

Begin by assembling the new Clutch Hub:

1. Place the flange (17b) on to the Clutch Hub (17a) so that the recessed area of the flange is against the splines. *Fig. 1*
2. Using snap ring pliers install the Snap Ring (17c) on to the Clutch Hub (17a)
3. The New Clutch Hub requires a new output shaft. Select the appropriate shaft and install the Thrust Washer (17d) against the splines on the output shaft (19). *Fig. 2*
4. Hold thrust washer in place with the Snap Ring (13).

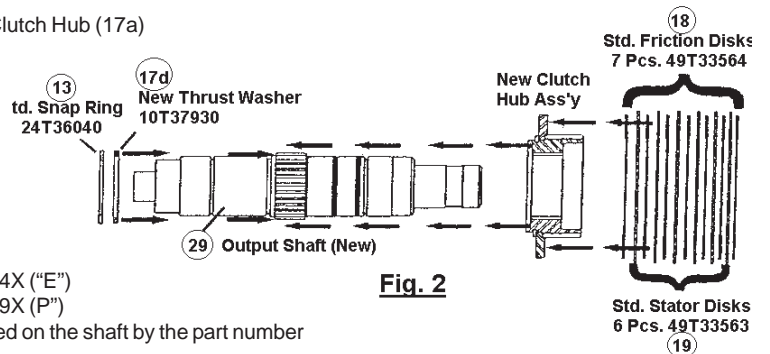
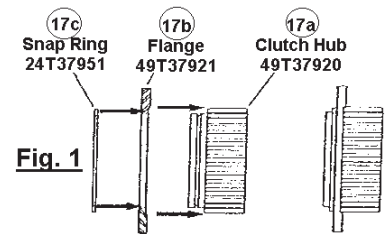

06T37933 = 06T36072X ("C")      06T37935 = 06T36074X ("E")  
 06T37934 = 06T36073X ("D")      06T37937 = 06T36799X ("P")  
 Current Inventory that has been reworked will have an "X" marked on the shaft by the part number

## INSTALLATION KITS

### ELEC/HYD SYSTEM - KIT NO. 48TK3882 (12V)

ITEM	QTY	PART NUMBER	DESCRIPTION
		<b>30T36270</b>	<b>Switch Ass'y (Incl 1,2,3,4)</b>
1	1	36MA1005	Switch Bracket
2	1	36M01006	Face Plate For Overspeed Light
		36T36271	Face Plate without light access
3	1	32MSR12V	Light Assembly (12 Volt)
4	1	30T35687	Rocker Switch
6	1	33T36299	Fuse Assembly
7	1	30T37954	Pressure Switch
8	1	34M18250	Female Spade Connector
9	1	34M18009	Ring Terminal
10	2	34M18187	Female Spade Connector
11	1	34M18002	Butt Splice
12	1	34T35872	Wire Harness
13	6	37M18000	Wire
14	1	37T35674	Grommet
N.S.	1	36MK1007	Bolt Kit (Incl w/30T36270+30T36543)
N.S.	1	43M05522	Elbow
		<b>For 24V Option Kit No. 48TK3891 Substitute:</b>	
		<b>30T36453</b>	<b>Switch Ass'y (Incl. 1&amp;2 above and 3&amp;4 below)</b>
3	1	32MSR24V	Light Assembly (24 Volt)
4	1	30T35712	Rocker Switch (24 Volt)

### INSTALLATION KIT WITH DIRECT ACTIVATION SOLENOID (NO HOSE KIT REQUIRED)

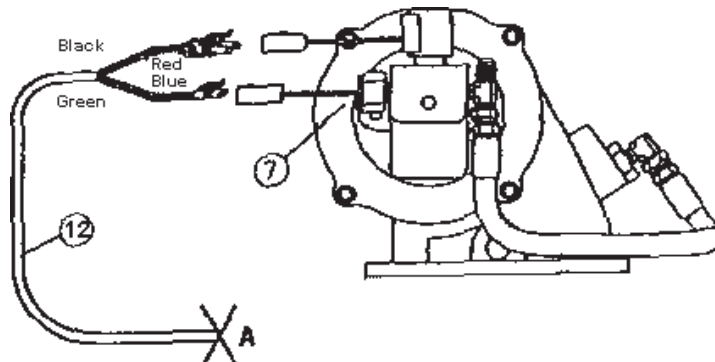

### CIRCUIT INSTALLATION WHEN USED *WITHOUT* OVERSPEED SWITCH

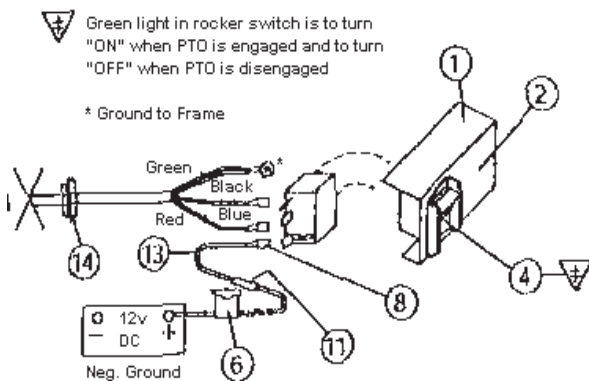

### CIRCUIT INSTALLATION WHEN USED *WITH* OVERSPEED SWITCH

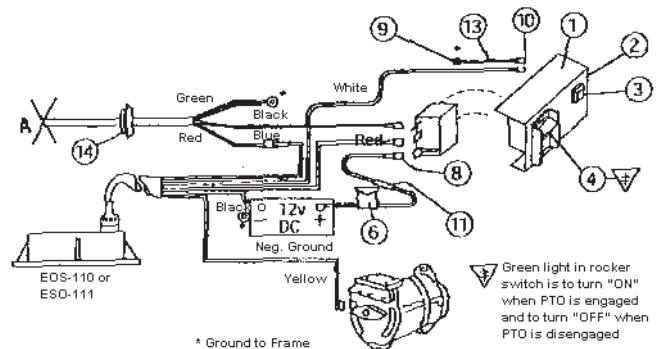



## PARTS LIST AND DESCRIPTION

ITEM	QTY	PART NUMBER	DESCRIPTION	ITEM	QTY	PART NUMBER	DESCRIPTION
1	1	03T36217	Input Gear (08) (50T/34T)	34	1	15T36123	Bearing Cov. Open ("C")
1	1	03T36216	Input Gear (07) (50T/31T)	35	6	19T32740	Capscrew ("C")
2	2	10T35776	Input Bearing	36	1	14T31499	Companion Flange ("C" Only)
3	1	18T35781	Shim (.122/.125)	37	1	21T20092	Washer ("C" Only)
		18T35782	Shim (.117/.120)	38	1	21T20526	Lock Washer ("C" Only if Required)
		18T35783	Shim (.112/.115)	39	1	19T38266	Capscrew ("C" Only)
4	4	19M38100	Capscrew	42	1	35T36092	Solenoid (12 Volt)
5	1	15T36206	Bearing Cover, Closed (CS12)			35T36447	Solenoid (24 Volt)
6	1	12T36081	O-Ring	43	4	25T21684	Pipe Plug
7	1	12T36207	O-Ring	44	2	19T36174	Set Screw
8	1	10T35994	Bearing	45	2	27T36173	Spring
9	2	26T36175	Roll Pin	46	1	13T35777	Gasket
10	1	21T36170	Drag Brake Plate (CS12)	47	1	25T35999	Plug
11	1	21T36172	Bronze Brake Disc (CS12)	48	1	25T35784	Orifice
12	1	21T36171	Drag Brake Rotor (CS12)	49	1	43T35867	Elbow
13	3	24T36040	Snap Ring	50	1	45T35865	Hose
14	2	10T35989	Thrust Race	51	1	43T36231	Tee
15	1	10T35991	Bearing	52	1	49T36283	Hose Clamp
16	1	02T36222	Bell Gear (08) (40T)	53	1	21T36448	Washer
16	1	02T36221	Bell Gear (07) (443T)			<b>43TK3881</b>	<b>Standard Hose Kit</b>
17	1	02T36113	Clutch Hub (Before 4/99)			<b>43TK3885</b>	<b>HD For R.S. Installation</b>
	1	49TA4136	Clutch Hub Assembly (4/99) (Includes:17a, 17b, 17c) (See Page 2)				
17a	1	49T37920	Clutch Hub (4/99)	54	1	45T36274	Hose (Std 28")
17b	1	49T37921	Clutch Flange (4/99)			45T36273	Hose (HD R.S. 57")
17c	1	24T37951	Snap Ring (4/99)	55	1	43M68014	Elbow
17d	1	10T37930	Thrust Washer (4/99) (Used w/49TA4136 Only)	56	1	43T36445	Elbow (use as needed)
18	7	49T33564	Friction Disc			<b>20MK1001</b>	<b>Mounting Bolt Kit (Incl 57,58)</b>
19	11	49T33563	Spacer Disc (Before 4/99)	57	2	20T35779	Alignment Stud
	6	49T33563	Spacer Disc (4/99)	58	8	19T35778	12 Pt. Capscrew (30mm)
20	1	27T36112	Spring	59	1	49T36493	Protector
21	1	49T36114	Piston	<b>N.S.</b>	<b>1</b>	<b>48TK3900</b>	<b>Installation Kit (12v) Incl:</b> Shift Kit, Gasket Pack, Stud Kit, Std. Hose Kit
22	1	12T36054	O-Ring			<b>48TK3901</b>	<b>Installation Kit (24v) Incl:</b> Shift Kit, Gasket Pack, Stud Kit, Std. Hose Kit
23	2	12T36053	O-Ring	<b>N.S.</b>	<b>1</b>	<b>CS12-GSK</b>	<b>Gasket Kit Incl:</b> (1)6, (1)7, (1)22, (2)25, (1)32, (1)33, (1)46
24	1	49T36115	Piston Cup	<b>N.S.</b>	<b>1</b>	<b>CS12-RBK</b>	<b>Rebuild Kit Incl:</b> (2)2, (1)3, (1)6, (1)7, (1)8, (2)9, (1)11, (3)13, (2)14, (1)15, (7)18, (11)19, (1)22, (2)23, (2)25, (1)32, (1)33, (2)45, (1) 46
25	2	12T35774	O-Ring				
26	1	19T35785	Set Screw				
27	1	07T35780	Idler Shaft				
28	1	01T36204	Housing (1 Arrangement)				
		01T36202	Housing (3 Arrangement)				
Output Shafts (OS) were changed 4/99 to accommodate the two-piece clutch hub (17). When replacing shaft in PTO prior to 4/99, clutch hub assembly (17) and washer (17d) must be added to required parts.							
29	1	06T37933	OS "C" replaces 06T36072	* Date Code Is Located Under PTO Model Label			
30	1	10T35775	Output Bearing				
32	1	12T35773	O Ring				
33	1	11T37795	Seal				

**PLEASE NOTE:** Some items listed are **"SPECIAL ORDER ONLY"**.  
 Some components available in kit form only.  
 For more information please contact the Technical Department at MEGA Pacific