

POWER TAKE-OFF **4.2.79.8.**

FOR GEARBOX :

ISUZU MSA, 5D, 5G, 5P, 5S
MXA 5R, 5S, 6R

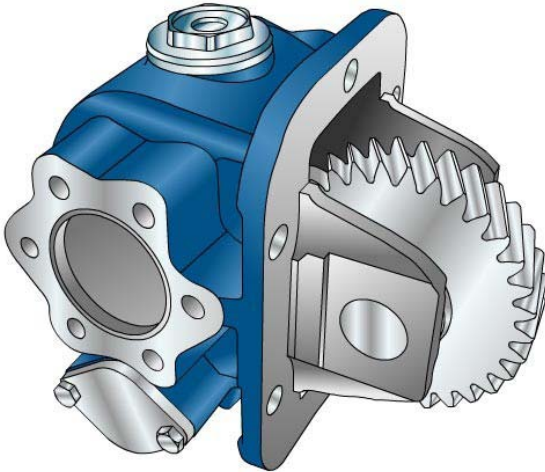

Technical data: refer to transmission application manual.

OUTPUT TORQUE:

20 kgm. (increase of 50% for intermittent service).

WEIGHT: kg. 9,1

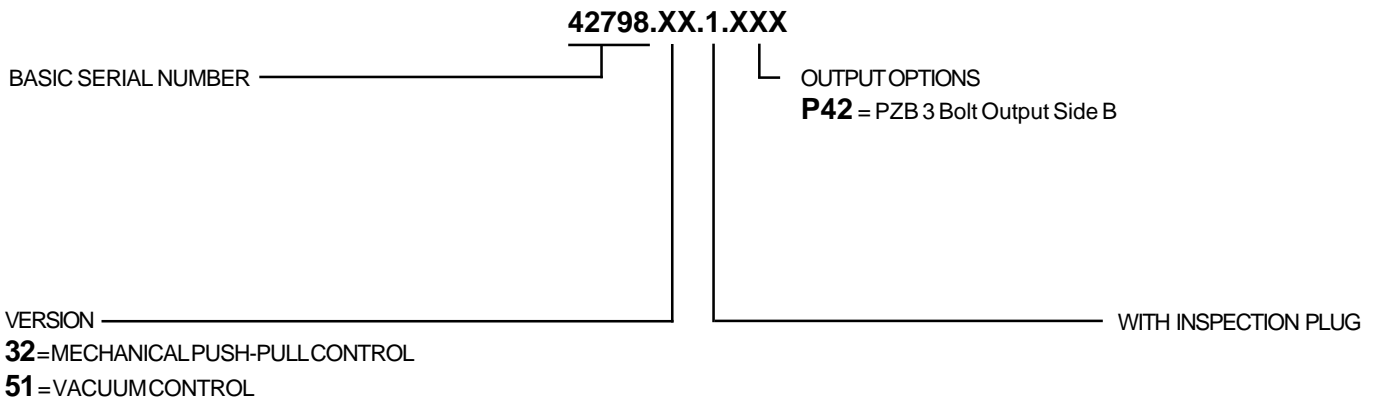

OUTPUT SHAFT OPTION

DESCRIPTION	CODE
Direct mounting PZB pumps-3 bolt mtg. flange (see chart Y type A)	205P0020000
Direct mounting PZB pumps-4 bolt ISO flange (see chart Y type C)	205X0450000
Flange K1300 Spicer for remote drive (see chart X group A)	205F5970000

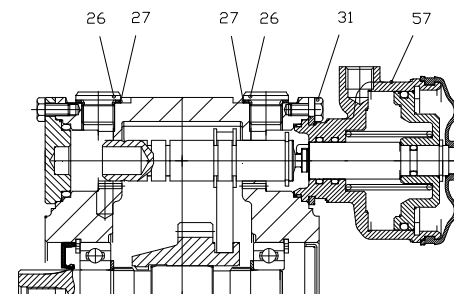
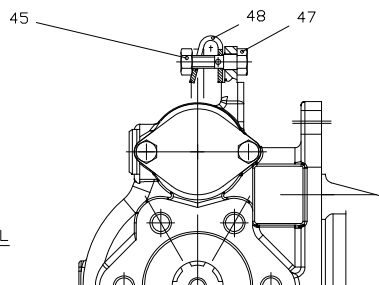
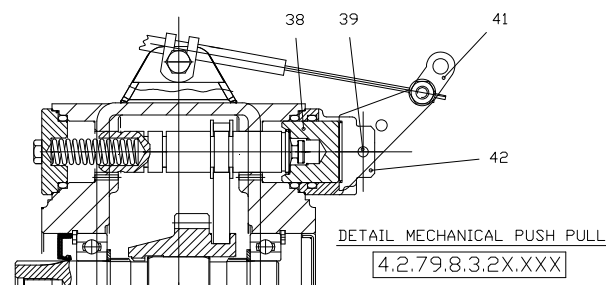

OPTIONAL SWITCH KIT

DETAILED PNEUMATIC SHIFTING

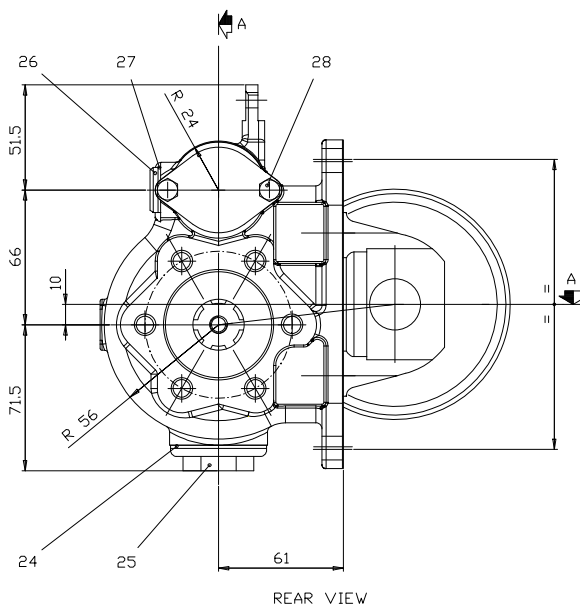
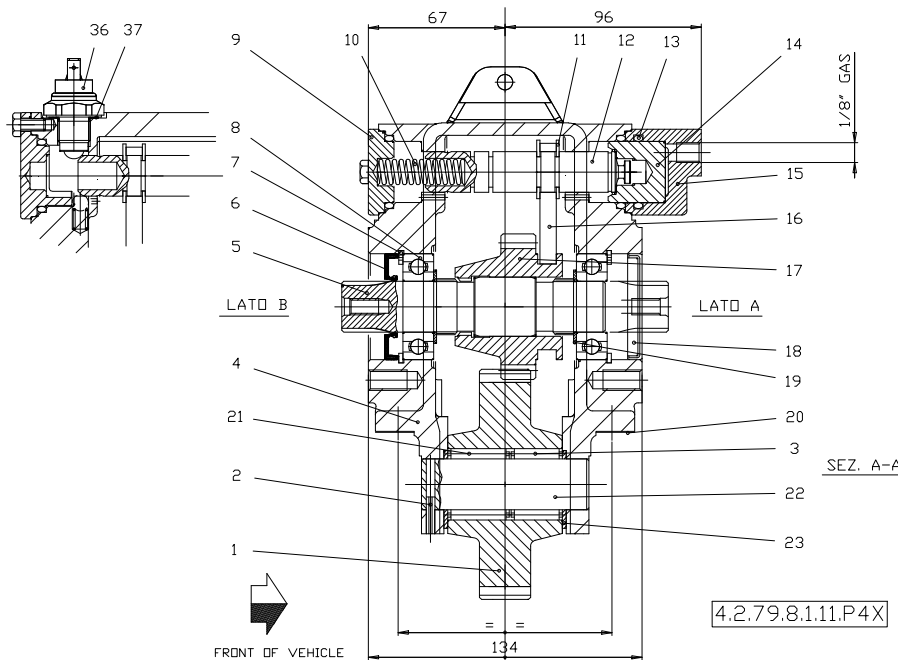

4.2.79.8.1.11.P4X

REF	CODE	QTY	DESCRIPTION	NOTE
01	1.11.01.151.00	1	GEAR Z 33	
02	0.05.02.001.00	1	ROLL PIN 4x18 UNI 6873	
03	0.10.06.008.00	1	NEEDLE CAGE K25x35x25	☆
04	1.01.02.156.00	1	HOUSING (PTD 42798)	
05	1.13.01.178.00	1	SHAFT	
06	0.08.01.025.00	1	SEAL 25x52x7	☆
07	0.07.02.004.00	2	CIRCLIP 52I UNI 7437	
08	0.10.01.001.00	2	BEARING 6205	☆
09	1.24.01.902.00	1	PLUG	
10	1.28.01.501.00	1	SPRING	
11	0.07.03.001.00	2	CIRCLIP RS15 UNI 7434	
12	1.14.03.100.00	1	SHAFT SELECTOR	
13	0.08.02.028.00	3	DRING DR 4118	☆
14	1.21.01.901.00	1	PISTON PNEUMATIC	
15	1.08.01.501.00	1	CAP PNEUMATIC	
16	1.22.01.050.00	1	FORK	
17	1.11.07.164.00	1	GEAR Z 19	
18	0.12.01.044.00	1	WELSH PLUG 52x7	☆
19	1.26.01.107.00	2	SHIM	
20	1.29.01.501.00	1	GASKET 6F spessore 0.5	■
21	0.10.06.007.00	1	NEEDLE CAGE K25x35x30	☆
22	1.14.01.048.00	1	SHAFT	
23	1.27.01.033.00	2	WASHER	
24	0.08.99.005.00	1	GASKET 1" Gas	☆
25	0.12.01.074.00	1	PLUG 1" Gas	
26	0.12.01.062.00	2	PLUG M16x1.5	●
27	0.04.01.136.00	2	WASHER 16x22x1.5	Ⓐ
28	0.01.01.022.00	2	SCREW TE M6x12 UNI 5739	△
29	0.04.04.004.00	2	WASHER schnorr 6	
30	0.01.03.110.00	2	SCREW TCEI M6x35 UNI 5931	△

REF	CODE	QTY	DESCRIPTION	NOTE
31	0.01.01.022.00	4	SCREW TE M6x12 UNI 5739	※△
32	0.00.99.128.00	1	ACTUATOR 12 V	
	0.00.99.120.00	1	ACTUATOR 24 V	
33	0.04.01.136.00	1	WASHER 16x22x1.5	●
34	0.99.00.289.00	1	INDICATOR Merit N.A.	
35	0.12.01.103.00	1	PROTECTION COVER	●
36	205E5900000	1	INDICATOR TDS N.A.	
37	0.04.01.151.00	1	WASHER 16x24x0.5	
38	1.21.01.902.00	1	PISTON MECHANICAL	
39	0.05.02.033.00	1	ROLL PIN 5x25 UNI 6873	
40	0.99.00.280.00	1		
41	0.99.00.281.00	1	LEVER	
42	1.24.01.903.00	1	MECHANICAL COVER	
43	0.07.03.009.00	1	CIRCLIP 6 DIN 6799	
44	0.99.00.284.00	1		
45	0.03.01.001.00	2	CAPSCREW M6 UNI 5588	
46	0.04.01.040.00	2	WASHER 6MM	
47	1.30.01.501.00	2	SCREW	
48	1.99.00.181.00	1	HOSE CLAMP	
49	0.07.01.035.00	1	CIRCLIP 20E UNI 7436	●
50	0.12.01.062.00	1	PLUG M16x1.5	
51	0.04.01.136.00	1	WASHER 16x22x1.5	
52	0.08.02.028.00	1	DRING DR 4118	☆
53	0.11.01.001.00	1	BALL 5/16"	
54	1.28.01.514.00	1	SPRING	
55	1.24.01.904.00	1	PLUG	
57	2.05.625.0000	1	VACUUM KIT	

※ Set up with Loctite type*243' ● Tightening torque: 50±5 Nm △ Tightening torque: 7±1 Nm ■ GASKET INCLUDED IN PTD KIT ☆ ASSEMBLE WITH GREASE TYPE *Polimer 400*(sigma *OCR*)