

**POWER TAKE-OFF 3.2.79.5.**

**FOR GEARBOX :**

DAIHATSU M50, M52  
TOYOTA M40, M50, M51, M52  
MD4, MD5



Technical data: refer to transmission application manual.

**OUTPUT TORQUE:**

25 kgm. (increase of 50% for intermittent service).

**WEIGHT:** kg. 9,1

**3.2.79.5.X.XX.1.X**

BASIC SERIAL NUMBER \_\_\_\_\_

SHIFTING \_\_\_\_\_

**1** = PNEUMATIC

**3** = MECHANICAL PUSH-PULL

COMPANION FLANGE FOR REMOTE TRANSMISSION

**0** = NO OPTION

**1** = SPICER 1120 CODE 2.05.054.0000

**2** = SPICER 1300 CODE 2.05.055.0000

**3** = DIN 00 CODE 2.05.056.0000

**6** = DIN 10 CODE 2.05.077.0000

OUTPUT SHAFT OPTION

**OUTPUT SHAFT OPTION**

DESCRIPTION	CODE	
	SIDE A	SIDE B
For remote transmission (see chart X group A)	<b>01</b>	<b>02</b>
Direct mounting PZB pumps-3 bolt mtg. flange (see chart Y type A)	<b>03</b>	<b>04</b>

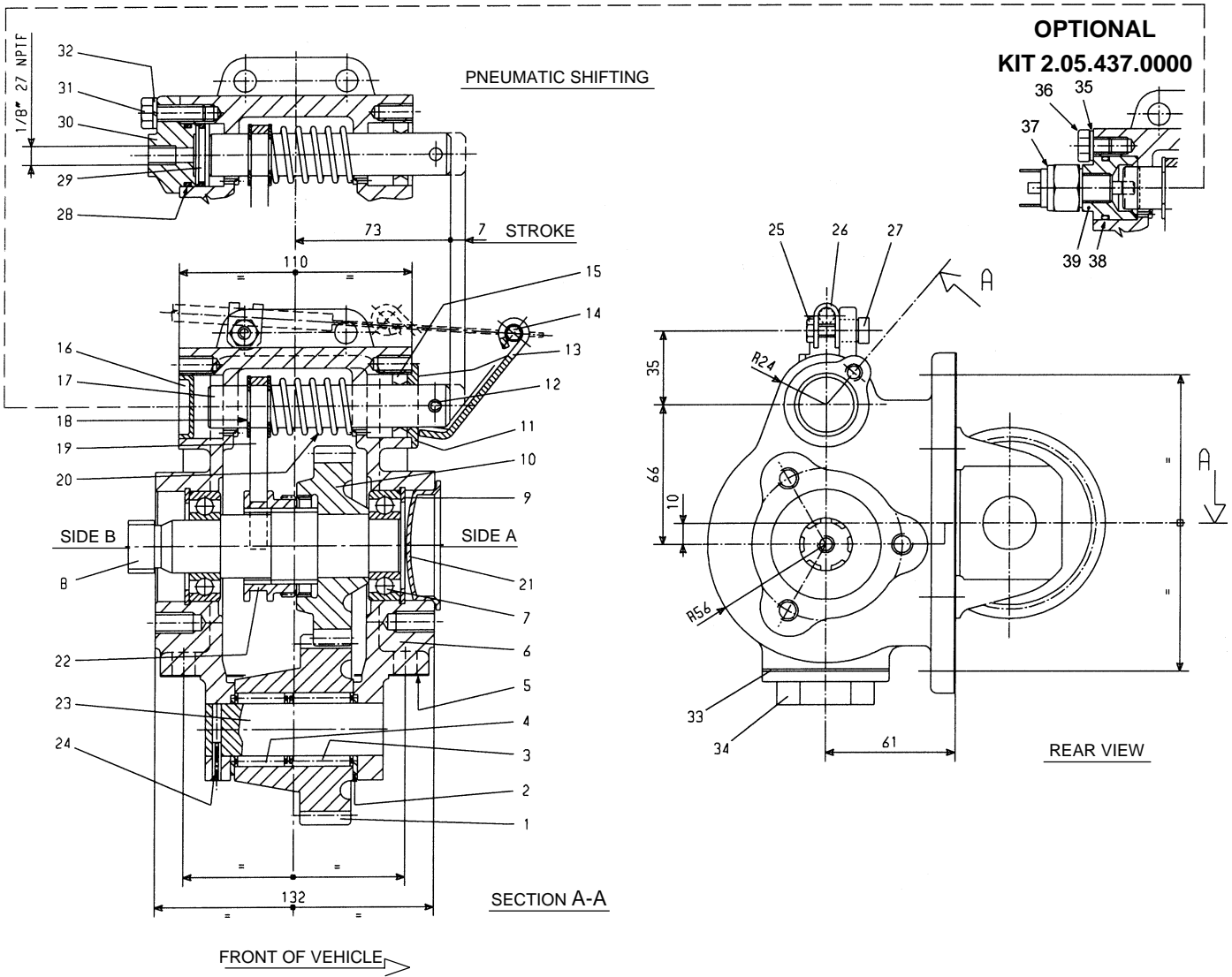

REF.	CODE	DESCRIPTION	QT.
1	1.11.01.080.00	Gear 27 T	1
2	1.27.01.033.00	Washer 43x25,2x2	2
3	0.10.06.007.00	Needle cage K25x35x30	1
4	0.10.06.008.00	Needle cage K25x35x25	1
5	1.29.01.001.00	Gasket PTO/gearbox SAE 6-bolt/metr.0,5	1
6	1.01.02.090.00	Housing	1
7	0.10.01.001.00	Bearing 6205	2
8	1.13.01.129.00	Shaft	1
9	0.07.02.004.00	Circlip 52i UNI 7437	2
10	1.11.10.090.00	Gear 29 T	1
11	1.27.02.090.00	Washer	1
12	0.05.02.019.00	Roll pin 6x28 UNI 6873	1
13	1.23.00.041.00	Lever	1
14	0.99.00.132.00	Clamp with head screw art.1713	1
15	0.08.01.005.00	Seal 20x30x7	1
16	0.12.01.055.00	Screw plug 30x6	1
17	1.14.03.073.00	Shaft	1
18	0.07.03.001.00	Circlip RS15 UNI 7434	2
19	1.22.01.050.00	Fork	1
20	1.28.01.084.00	Coil spring	1
21	0.12.01.044.00	Plug 52x7	1

REF.	CODE	DESCRIPTION	QT.
22	1.17.02.069.00	Splined sleeve	1
23	1.14.01.048.00	Shaft	1
24	0.05.02.001.00	Roll pin 4x18 UNI 6873	1
25	0.01.01.027.00	Capscrew TE M6x20 UNI 5739 CL RES 8.8	1
26	1.99.00.181.00	Hose clamp	1
27	1.30.02.020.00	Hex nut	1
28	0.08.02.013.00	O-Ring OR 3100	2
29	1.21.02.033.00	Piston	1
30	1.24.01.089.00	Cover	1
31	0.01.01.002.00	Capscrew TE M8x25 UNI 5739 CL RES 8.8	1
32	0.04.02.002.00	Lockwasher 8,4 UNI 1751	1
33	0.08.99.005.00	Gasket 1"	1
34	0.12.01.074.00	Retainer 1" Gas	1
<b>OPTIONAL: KIT SWITCH 2.05.437.0000</b>			
35	0.04.01.065.00	Washer 8,4 DIN 433	1
36	0.01.01.029.00	Capscrew TE M8x10 UNI 5739 CL RES 8.8	1
37	0.99.00.226.00	Indicator switch	1
38	0.08.02.013.00	O-Ring OR 3100	1
39	1.99.00.290.00	Bracket for switch	1