

CS24/25 SERIES CLUTCH SHIFT PTO

PARTS LIST AND SERVICE MANUAL

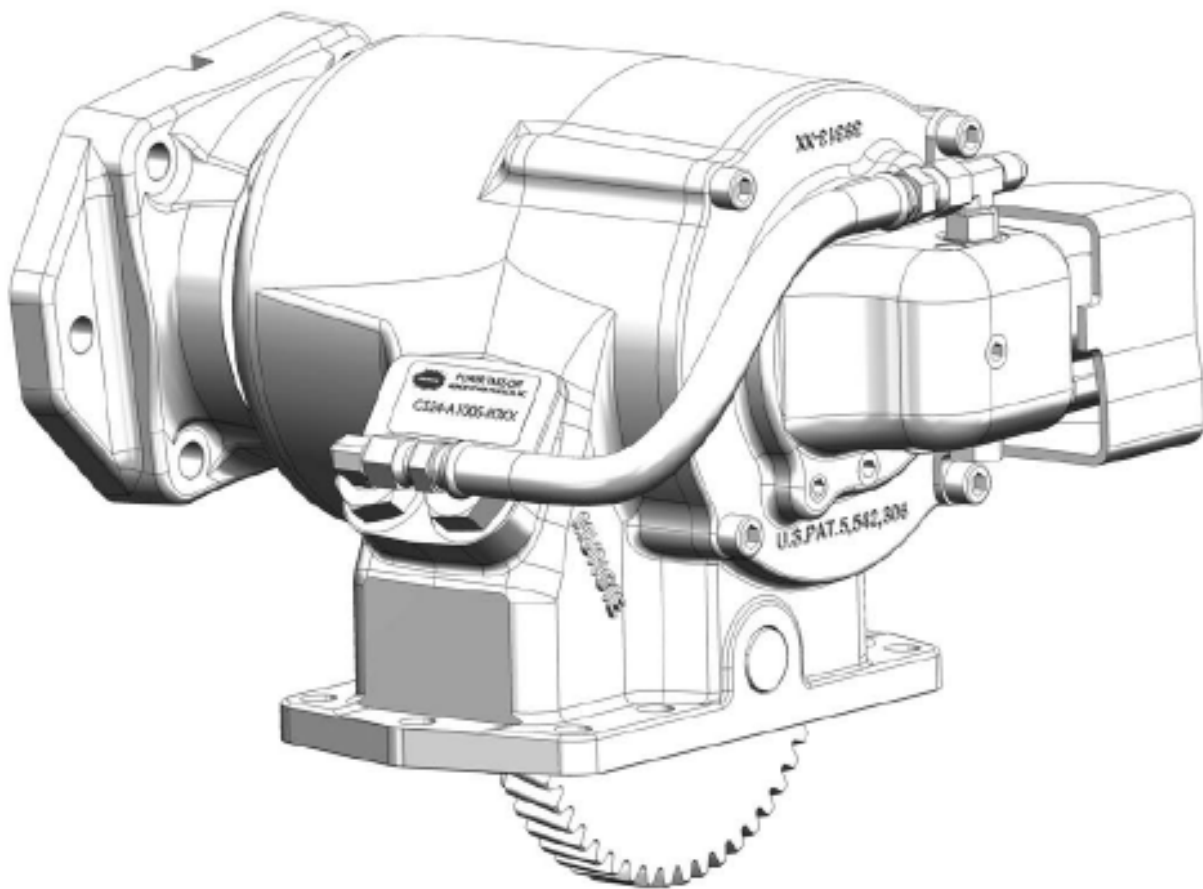

MEGA NOTE: Several items shown in this catalogue are special order kits only. Contact Mega sales department for further information.

CS24/25 PTO EXPLODED VIEWS

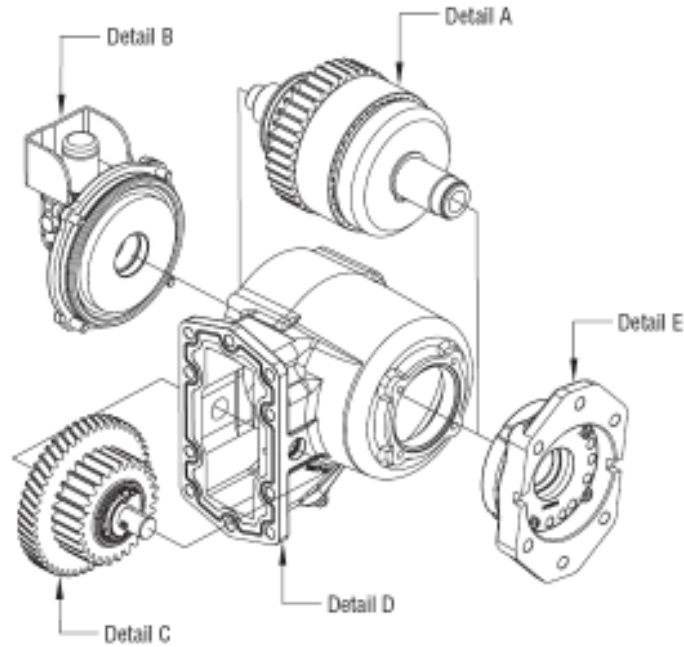

DETAIL A – OUTPUT SHAFT ASSEMBLY

CS24/25 STANDARD OUTPUT SHAFT ASSEMBLY

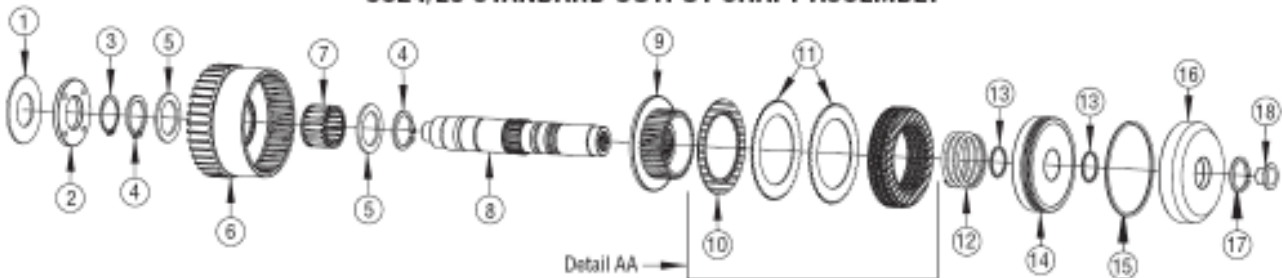

DETAIL AA - STANDARD CLUTCH PACK - DISC LOCATIONS*

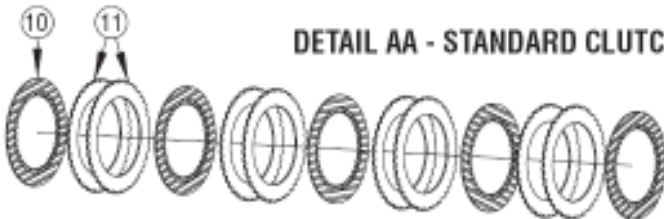

*The standard clutch pack assembly contains a pair of stator plates stacked between each friction disc. The assembly should begin and end with a friction disc.

CS24/25 "I", "D" & "Z" OUTPUT SHAFT ASSEMBLY

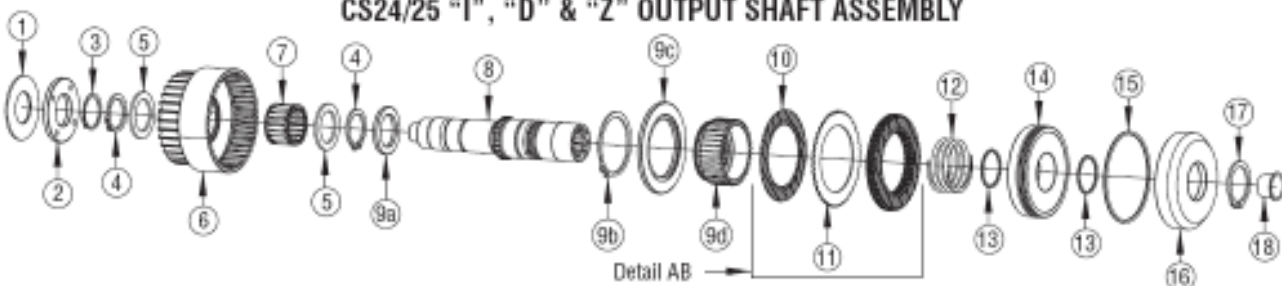

CS24/25 PTO EXPLODED VIEWS

DETAIL AB - "I", "D" & "Z" CLUTCH PACK - DISC LOCATIONS**



** The "I", "D" & "Z" clutch pack assembly contains a single stator plate stacked between each friction disc. The assembly should begin and end with a friction disc.

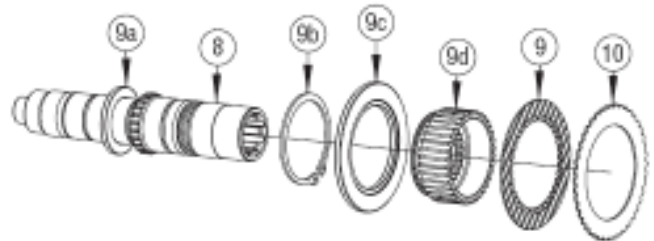

Note: The output shaft for the "I", "D" & "Z" output option is a larger diameter shaft and requires different clutch pack components. The 4-piece clutch hub is assembled by inserting the clutch hub (9d) into the flange (9c). These items are held together with a snap ring (9b) and the spacer (9a) is placed on the output shaft (8) **BEFORE** installing the clutch hub assembly.

DETAIL B - END COVER ASSEMBLY

CS25 COVER ASSEMBLY DIRECT SOLENOID

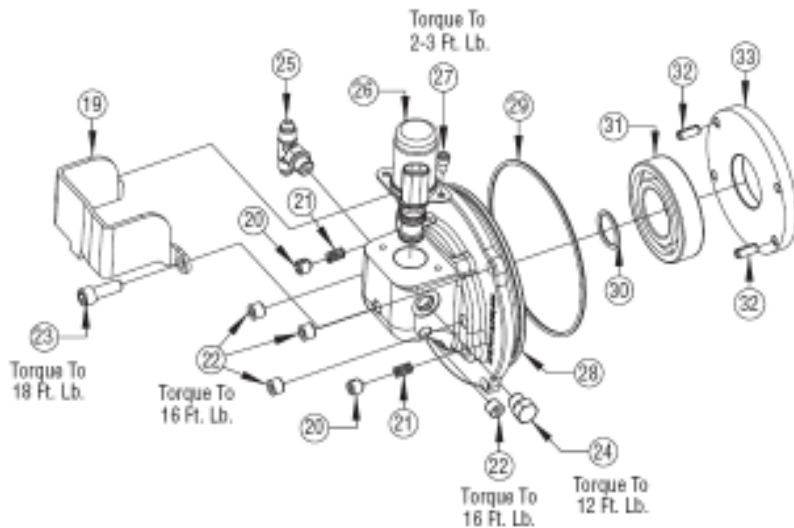

CS25 COVER ASSEMBLY REMOTE SOLENOID

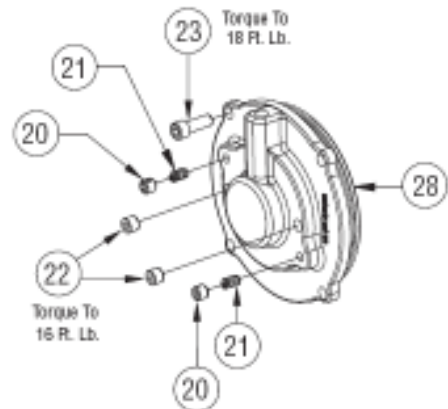

DETAIL C INPUT SHAFT ASSEMBLY

CS24/25 INPUT SHAFT

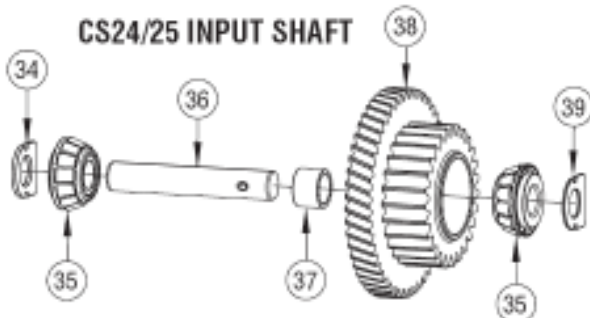

DETAIL D PTO HOUSING ASSEMBLY

CS24/25 HOUSING

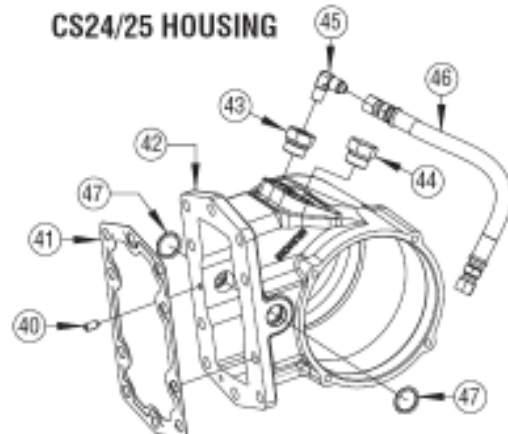

CS24/25 PTO EXPLODED VIEWS

DETAIL E – OUTPUT OPTIONS

STANDARD HYDRAULIC OUTPUT – “K”, “P” & “Z” SHOWN

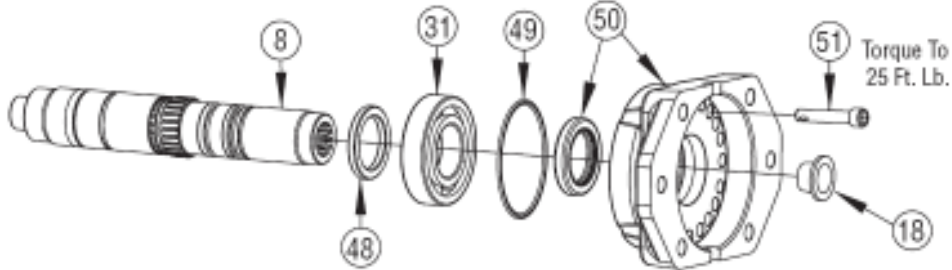

“B” OUTPUT OPTION

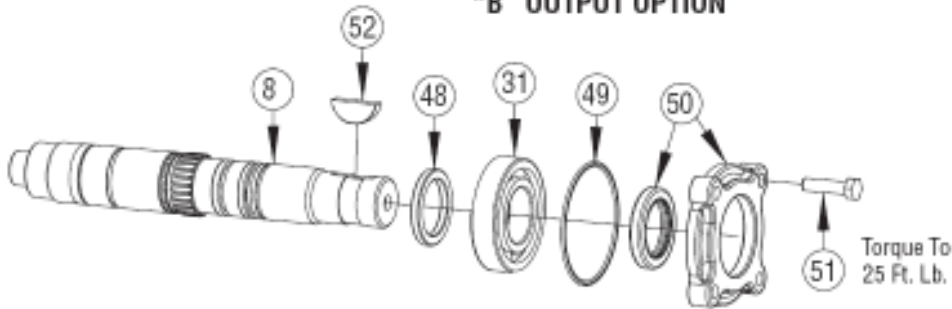

DETAIL E - “C” & “2” OUTPUT OPTION

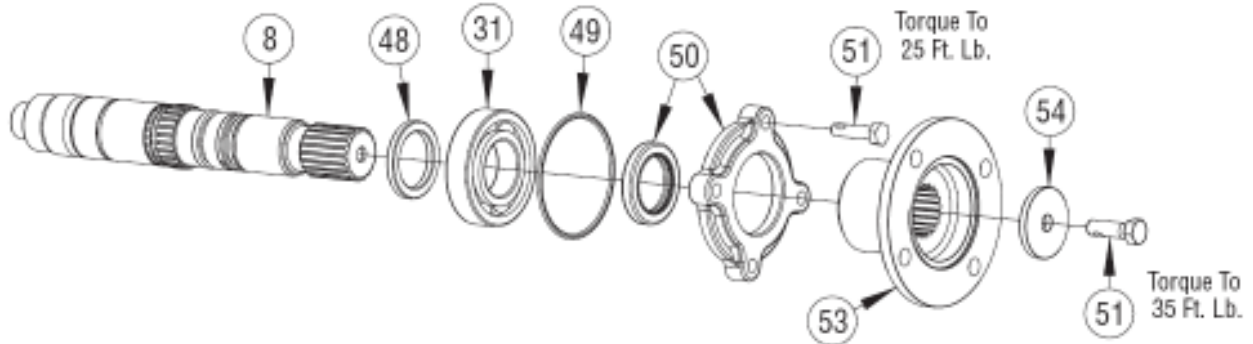

DETAIL E - “I”, “D” & “Z” OUTPUT OPTION

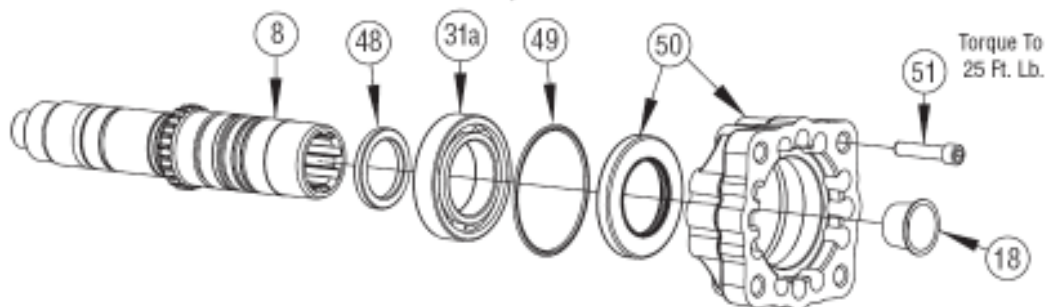



PARTS LIST & DESCRIPTION

ITEM	QTY	PART NO.	DESCRIPTION
01	1	21T36511	Washer (CS24, CS26)
02	1	21T36512	Plate (CS24, CS26)
03	1	24T27240	Snap Ring
04	2	24T35480	Snap Ring
05	2	21T29017	Thrust Washer
06	1	See Table A*	Bell Gear
07	1	10T36285	Needle Roller Bearing
08	1	See Table B*	Output Shaft
09	1	02T38792	Clutch Hub
09a	1	21T38907	Washer ("I", "D" & "Z")
09b	1	24T37951	Snap Ring ("I", "D" & "Z")
09c	1	49T38818	Flange ("I", "D" & "Z")
09d	1	49T38819	Clutch Hub ("I", "D" & "Z")
10	5	49T33564	Friction Disc
	5	49T38231	Friction Disc (CS26 Only)
11	8	49T40641	Spacer Disc
	8	49T38230	Spacer Disc (CS26 Only)
	4	49T40641	Spacer Disc ("I", "D" & "Z")
12	1	27T36112	Spring
13	2	12T36471	O-Ring
	2	12T36053	O-Ring ("I", "D" & "Z")
14	1	49T36463	Piston
	1	49T38552	Piston ("I", "D" & "Z")
15	1	12T36472	O-Ring
16	1	49T36464	Piston Cup
	1	49T38553	Piston Cup ("I", "D" & "Z")
17	1	24T36470	Snap Ring
	1	24T36040	Snap Ring ("I", "D" & "Z")
18	1	25T35724	Cap Plug ("G", "K", "Q" & "S")
	1	25T35725	Cap Plug ("P")
	1	25T37789	Cap Plug ("I" & "D")
	1	25T35936	Cap Plug ("Z")
	1	25T37387	Cap Plug ("T")
19	1	49T39511	Protector
20	2	19T36174	Setscrew
21	2	27T36173	Spring
22	4	25T21684	Pipe Plug
23	4	19T36588	Capscrew
24	1	25T41463	Plug
25	1	43T36231	Tee
26	1	35T40860	Solenoid 12V
	1	35T40864	Solenoid 24V
27	2	19T40859	5mm Capscrew
28	1	15T40862	Bearing Cover, Closed (CS24) (w/ Drop in Solenoid)
	1	15T40478	Bearing Cover, Closed (CS25) (w/o Drop in Solenoid)
29	1	12T36197	O-Ring
30	1	12T36081	O-Ring
31	2	10T21017	Bearing
	1	10T21017	Bearing ("I", "D" & "Z")
31a	1	10T38248	Bearing ("I", "D" & "Z")
32	2	26T36175	Roll Pin (CS24, CS26)
33	1	21T36473	Plate (CS24, CS26)
34	1	See Table C*	Bearing Shim
35	2	10T35776	Tapered Roller Bearing
36	1	07T35780	Idler Shaft
37	1	See Table D*	Cone Spacer
38	1	See Table E*	Input Gear
39	1	18T41452	Bearing Shim (.0620"/.0800")
40	1	19T35785	Set Screw

ITEM	QTY	PART NO.	DESCRIPTION
41	1	13T35777	Gasket
42	1	See Table F*	PTO Housing
43	1	25T35784	Orifice
44	1	25T35999	Plug
45	1	43T35867	Elbow
46	1	45T36308	Hose
47	2	12T35774	O-Ring
48	1	28T36546	Spacer ("G", "K", "P", "Q", "S", "T" & "6")
	1	28T39404	Spacer ("I")
49	1	12T36751	O-Ring
	1	12T38344	O-Ring ("I", "D" & "Z")
50	1	See Table G*	Flange/Seal Assembly
51	4	19T34717	Capscrew ("B", "C" & "Z")
	4	19T34462	Socket Capscrew ("K" & "P" Hyd.)
	4	19T39257	Socket Capscrew ("G", "Q" & "S" Hyd)
	4	19M84478	Socket Capscrew ("I" & "D")
	4	19T38249	Socket Capscrew ("Z")
	1	19T38266	Capscrew ("C", "X" & "Z")
52	1	26T01627	Woodruff Key
53	1	14T37378	"Z" Companion Flange
	1	14T37357	"C" Companion Flange
54	1	21T20092	Flat Washer ("C", "X" & "Z")
N.S.	1	48TK5028	Installation Kit (12V) Includes: Shift Kit, Gasket Pack, Stud Kit & Std. Hose Kit
N.S.	1	48TK5038	Installation Kit (24V) Includes: Shift Kit, Gasket Pack, Stud Kit & Std. Hose Kit
N.S.	1	48TK5234	Installation Kit (12V) Includes: Shift Kit, Gasket Pack, Stud Kit & Special Hose Kit (17")
N.S.	1	48TK4708	Installation Kit (12/24V) "P" Option Includes: Shift Kit, Gasket Pack, Stud Kit, Std. Hose Kit, Pressure Switch & Pressure Switch Fittings
N.S.	1	CS24-GSK	Gasket Kit Includes: (2)13, (1)15, (1)29, (1)30, (1)40, (2)46, (1)48, (1)11T37790 & (1)12TK3902
N.S.	1	CS24-GSK-I2	Gasket Kit Includes: (2)13, (1)15, (1)29, (1)30, (1)40, (2)46, (1)48, (1)11T37795 & (1)12TK3902
N.S.	1	CS24-RBK	Rebuild Kit Includes: (1)1, (1)3, (2)5, (5)10, (8)11, (1)12, (2)13, (1)15, (1)17, (2)21, (1)29, (1)30, (2)31, (1)34, (2)35, (1)40, (2)46, (1)48, (1)11T37790 & (1)12TK3902
N.S.	1	CS24-RBK-I2	Rebuild Kit Includes: (1)1, (1)3, (2)4, (2)5, (5)10, (8)11, (1)12, (2)13, (1)15, (1)17, (2)21, (1)29, (1)30, (1)31, (1)31a, (1)34, (2)35, (1)40, (2)46, (1)48, (1)11T37795 & (1)12TK3902
N.S.	1	CS26-RBK	Rebuild Kit Includes: (1)1, (1)3, (2)4, (2)5, (5)10, (8)11, (1)12, (2)13, (1)15, (1)17, (2)21, (1)29, (1)30, (2)31, (1)34, (2)35, (1)40, (2)46, (1)48, (1)11T37790 & (1)12TK3902
N.S.	1	48TK4054	Conversion Kit to CS25 12V
N.S.	1	48TK4055	Conversion Kit to CS25 24V

* Tables A, B, C, D, E, F, & G are located on page 6.



No. 1 in Transport Hydraulics



TABLES A, B, C, D, E, F & G

Table A – Bell Gear (Item 6)

PART NO	DESCRIPTION
02T39319	Bell Gear 05 (38 T)
02T36466	Bell Gear 06 (36 T)
02T36467	Bell Gear 07 (34 T)
02T36468	Bell Gear 08 (32 T)
02T36469	Bell Gear 10 (30 T)
02T36542	Bell Gear 12 (27 T)
02T38832	Bell Gear 15 (24 T)

Table B – Output Shaft (Item 8)

PART NO	DESCRIPTION
06T36452	Output Shaft "B" 1.3" Rd.
06T37373	Output Shaft "C" or "2"
06T39405	Output Shaft "D" Euro
06T38549	Output Shaft "G" DANA SPECIAL
06T40728	Output Shaft "I"
06T38547	Output Shaft "K" 7/8 – 13 SPL, & "6"
06T38550	Output Shaft "P" 1" – 15 SPL
06T38548	Output Shaft "Q" & "S" 7/8 – 13 SPL
06T37337	Output Shaft "T"

Table C – Input Bearing Shim (Item 34)

PART NO	DESCRIPTION	DIMENSION
18T41437	Bearing Shim	(.1150"/.1130")
18T41438	Bearing Shim	(.1175"/.1155")
18T41439	Bearing Shim	(.1200"/.1180")
18T41440	Bearing Shim	(.1225"/.1205")
18T41441	Bearing Shim	(.1250"/.1230")
18T41442	Bearing Shim	(.1275"/.1255")
18T41443	Bearing Shim	(.1300"/.1280")
18T41444	Bearing Shim	(.1325"/.1305")
18T41445	Bearing Shim	(.1350"/.1330")
18T41446	Bearing Shim	(.1375"/.1355")
18T41447	Bearing Shim	(.1400"/.1380")
18T41448	Bearing Shim	(.1425"/.1405")
18T41449	Bearing Shim	(.1450"/.1430")
18T41450	Bearing Shim	(.1475"/.1455")
18T41451	Bearing Shim	(.1500"/.1480")

Table E – Input Gear (Item 38)

ASSY NO	DESCRIPTION	BASE GEAR
03TA4624	A1005 Input Gear (50T/21T)	03T35752
03TA4625	A1006 Input Gear (50T/23T)	03T35919
03TA4626	A1007 Input Gear (50T/25T)	03T35755
03TA4627	A1008 Input Gear (50T/27T)	03T35758
03TA4628	A1010 Input Gear (50T/29T)	03T35761
03TA4629	A1012 Input Gear (50T/32T)	03T36545
03TA4630	A1015 Input Gear (50T/35T)	03T38830
03TA4624	C9505 Input Gear (45T/21T)	03T40237
03TA4624	C9506 Input Gear (45T/23T)	03T40217
03TA4624	C9507 Input Gear (45T/25T)	03T40218
03TA4624	C9508 Input Gear (45T/27T)	03T40219
03TA4624	C9510 Input Gear (45T/29T)	03T40220
03TA4624	C9512 Input Gear (45T/32T)	03T40221
03TA4624	C9515 Input Gear (45T/35T)	03T40222

Table D – Cone Spacer (Item 37)

PART NO	DESCRIPTION	DIMENSION
18T38748	Cone Spacer	(0.743"/0.741")
18T38532	Cone Spacer	(0.740"/0.738")
18T38533	Cone Spacer	(0.737"/0.735")
18T38534	Cone Spacer	(0.734"/0.732")
18T38535	Cone Spacer	(0.731"/0.729")
18T38536	Cone Spacer	(0.728"/0.726")
18T38537	Cone Spacer	(0.725"/0.723")
18T38538	Cone Spacer	(0.722"/0.720")
18T38539	Cone Spacer	(0.719"/0.717")
18T38540	Cone Spacer	(0.716"/0.714")
18T38590	Cone Spacer	(0.713"/0.711")
18T38591	Cone Spacer	(0.710"/0.708")
18T38592	Cone Spacer	(0.707"/0.704")

The cone spacer installs between the tapered input bearings to set the bearing preload at .002" - .006" loose. Critical dimension. See page 3/10 for visual detail. Purchase input gear assembly (Item 38 – 03TAXXXX) which includes the correct cone spacer.

Table F – PTO Housing (Item 42)

PART NO	DESCRIPTION
01T41453	Housing (Std 1 Arrangement)
01T41454	Housing (Std 3 Arrangement)
01T41509	Housing (Std 1 Arrangement) ("I", "D" & "Z")
01T41510	Housing (Std 3 Arrangement) ("I", "D" & "Z")
01T41511	Housing (Std 1 Arrangement) (C95 Cat)
01T41512	Housing (Std 3 Arrangement) (C95 Cat)

Table G – Output Cover/Flange (Item 50)

PART NO	DESCRIPTION	COMPONENTS
15TA5220	"B", "C" & "2" Flange/Seal Assy.	Includes: 15T41683 Bearing Cap & 11T37790 Output Shaft Seal
14TA4817	"D" & "I" Flange/Seal Assembly	Includes: 14T39406 Hydraulic Flange & 11T37795 Output Shaft Seal
14TA3998	"G" Flange/Seal Assembly	Includes: 14T39137 Hydraulic Flange & 11T37790 Output Shaft Seal
14TA3996	"K" & "P" Flange/Seal Assembly	Includes: 14T37779 Hydraulic Flange & 11T37790 Output Shaft Seal
14TA3997	"Q" & "T" Flange/Seal Assembly	Includes: 14T39141 Hydraulic Flange & 11T37790 Output Shaft Seal
14TA3999	"S" Flange/Seal Assembly	Includes: 14T35464 Hydraulic Flange & 11T37790 Output Shaft Seal
14TA4818	"Z" Flange/Seal Assembly	Includes: 14T38343 Hydraulic Flange & 11T37795 Output Shaft Seal
14TA4819	"6" Flange/Seal Assembly	Includes: 14T38981 Hydraulic Flange & 11T37790 Output Shaft Seal

INSTALLATION KITS

CS24 INSTALLATION KIT

48TK5017 (12V) With Direct Activation Solenoid

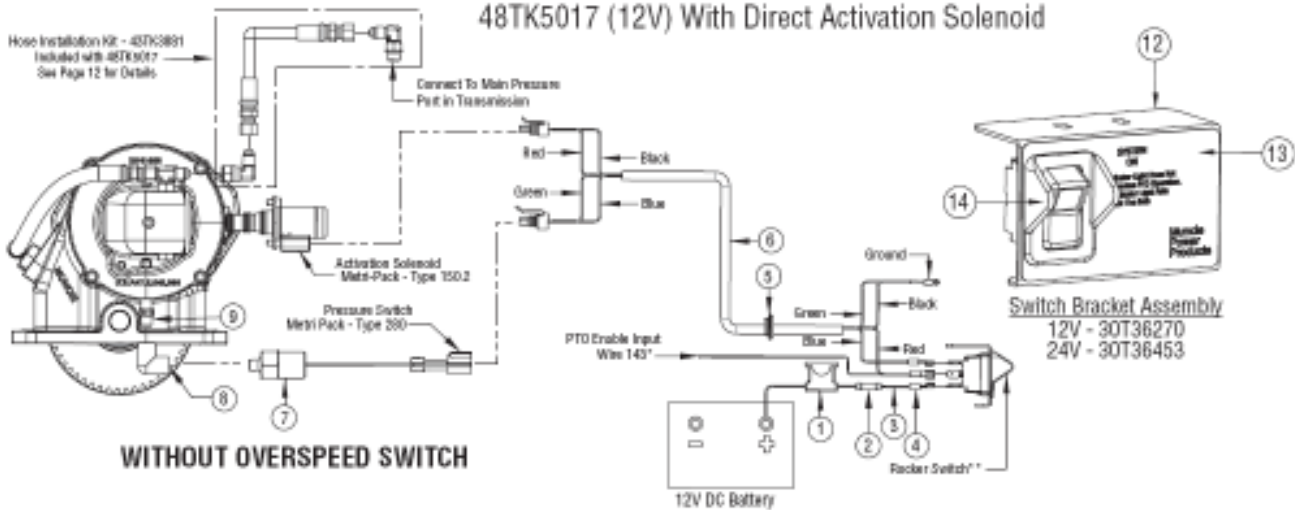

WITHOUT OVERSPEED SWITCH

Installation Kit - 48TK5017 (12V)

ITEM	QTY	PART NO	DESCRIPTION
1	1	33T36299	Fuse Assembly
2	1	34M18002	Butt Splice
3	6ft.	37M18000	Wire
4	1	34M18250	Female Spade Connector
5	1	37T35674	Grommet
6	1	34T40902	Wire Harness
7	1	30T37954	Pressure Switch
8	1	43T37959	Pipe Elbow
9	1	43T37958	Pipe Nipple
10	2	34M18009	Ring Terminal
11	3	34M18187	Female Spade Connector
12	1	36MA1005	Switch Bracket
13	1	36T36271	Face Plate (without Light Access)
14	1	30T35687	Rocker Switch (12V)
N.S.	1	36MK1007	Bolt Kit

*Allison TCM (Pin 43) — Clutchshift PTO's require a connection to the Allison "PTO Enable Input" circuits. Check the vehicle dealer or body builder's information for this location.)

**Green light in the rocker switch is to turn "ON" when the PTO is engaged and turn "OFF" when the PTO is disengaged.

For 24V Option (48TK5018)

Include items 12 & 13 and substitute item 14 with the 24V rocker switch (30T35712). This kit also comes with the 24V light assembly (32MSR24V) and the faceplate with light access (36MD1006).

WITH OVERSPEED SWITCH

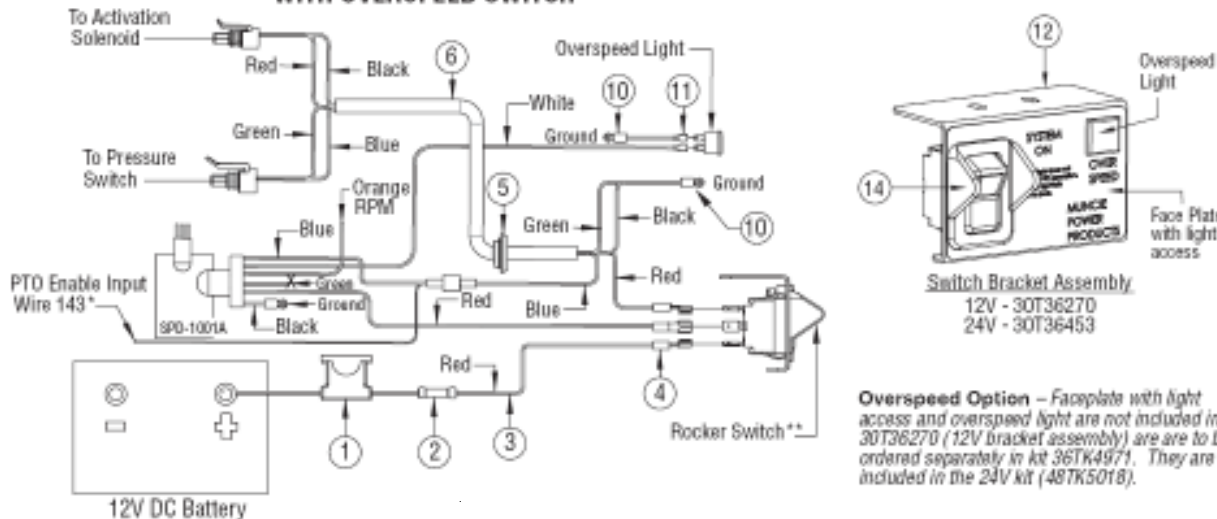

Overspeed Option - Faceplate with light access and overspeed light are not included in 30T36270 (12V bracket assembly) are to be ordered separately in kit 36TK4971. They are included in the 24V kit (48TK5018).

INSTALLATION KITS

CS25 Conversion Kit

48TK5076 (12V) With Remote Activation Solenoid. Use With Installation Kit 48TK5017 (Page 7). Hose Kit 43TK4036 included with conversion kit (see page 11).

Installation Kit - 48TK5076

ITEM	QTY	PART NO	DESCRIPTION
1	2	43T35867	1/8" NPT/JIC Elbow
2	1	43T37503	1/8" NPT/JIC Fitting
3	1	15TA5075	Cover Assembly
4	3	43M68014	7/16" - 20 Straight Thread Elbow
5	1	43T36231	Straight Branch Tree
6	1	35T37928	Valve 12VDC
7	4	45T36274	Hose Assembly
8	1	34T35872	Wire Harness
N.S.	1	43T36445	Elbow (Use as needed)
N.S.	2	19T36623	Capscrew
N.S.	2	22T35140	Nut
N.S.	2	21T37991	Lock Washer

WITHOUT OVERSPEED SWITCH SHOWN

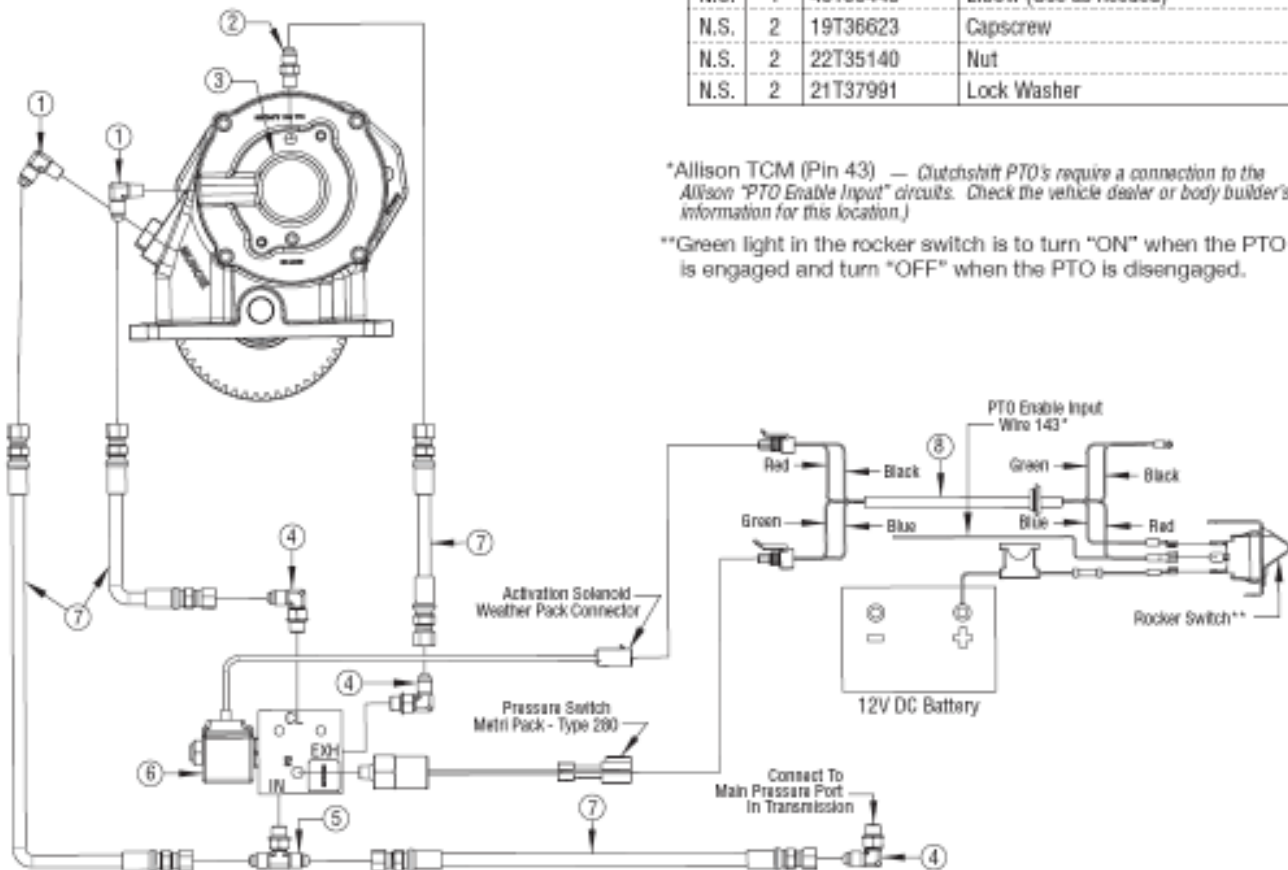

*Allison TCM (Pin 43) — Clutchshift PTO's require a connection to the Allison "PTO Enable Input" circuits. Check the vehicle dealer or body builder's information for this location.)

**Green light in the rocker switch is to turn "ON" when the PTO is engaged and turn "OFF" when the PTO is disengaged.

Refer to Page 7 to Install the CS25 Conversion Kit with an Overspeed Switch.

MODEL NUMBER CONSTRUCTION

CS 24 - A10 05 - H 3 K X

PTO Type

Clutch Shift - CS

Mounting

10 Bolt Mount, Design 2 - 24

10 Bolt Mount, Design 2 - 25
(w/Remote Solenoid)

10 Bolt Mount, Special - 26

Transmission CS Gear Data

Allison 10.16P RH - A10

Caterpillar 9.55P RH - C95

Speed Ratio

05 - .55:1

06 - .64:1

07 - .74:1

08 - .84:1

10 - .97:1

12 - 1.19:1

15 - 1.46:1

Shifter Type

Electric/Hydraulic (12Volt) - H

Electric/Hydraulic (24 Volt) - J

Less Activation Kit - P

Assembly Arrangement

1 or 3

Special Feature

X - None

A - Special SAE 2-bolt

B - Hose Kit (HD Trans. R.S.)

D - Pulse Generator & SPD1001A

U - Pulse Generator

2 - Hose Kit Special 36"

3 - Hose Kit Special 17"

Output Type

B - 1-1/4" Rd; 5/16" KW

C - 1.3" 20 Spline (1410 Flange)

D - 36mm - 8T (DIN 5462)

G - Special

I - 36mm - 8T (DIN 5462)

K - SAE "B" 2&4 Bolt 7/8" - 13T

P - SAE "BB" 2&4 Bolt 1.0" - 15T

Q - SAE "A" 2-Bolt 7/8" - 13T

S - SAE "B" 2-Bolt 7/8" - 13T

T - SAE "B" 2-Bolt 3/4" - 11T

X - 1.3" - 21 Spl.

Z - SAE "B" 2&4 Bolt; 1.3" - 14T

2 - 1.3" - 20T (DIN 100 Flange)

6 - SAE "B" 2-Bolt; 7/8" - 13T

CS24 ARRANGEMENT

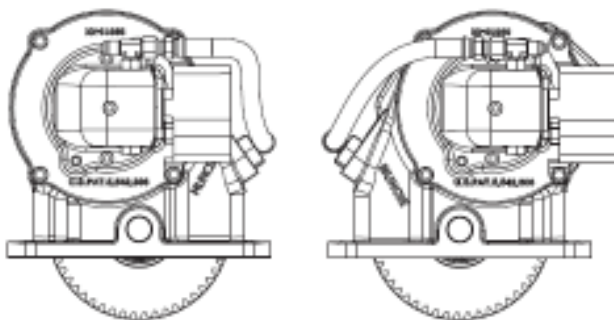

1 Assembly*

3 Assembly

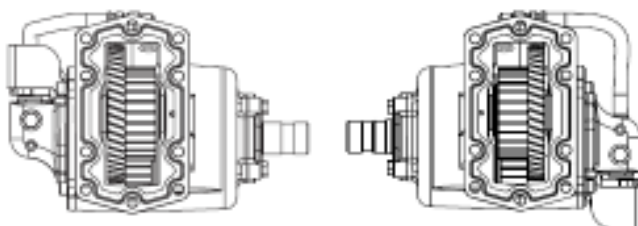

CS25 ARRANGEMENT

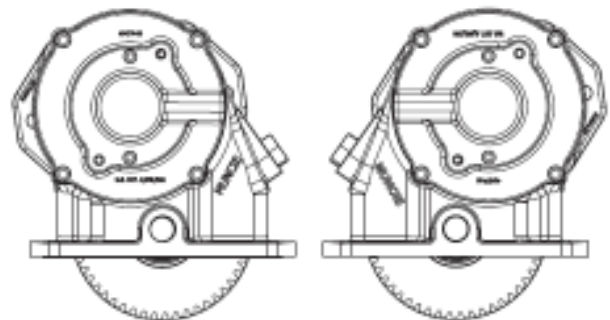

1 Assembly

3 Assembly

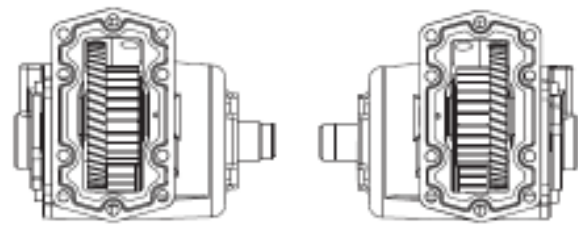

*The CS24 hose arrangement (items 42, 43 & 44) should be centered over the ratio gear as shown.

CS24 DISASSEMBLY AND REASSEMBLY

(REFERENCE EXPLODED VIEWS ON PAGES 2, 3 & 4)

DISASSEMBLY PROCEDURE

1. Remove the CS24 input gear (38) by removing the set screw (40) in the mounting pad and driving the idler shaft (35) from the housing (42).
2. Remove the set screws (20) from the bearing cover (28) which hold the drag brake springs (21). Position the housing so the springs can fall from the housing.
3. Remove the four large socket capscrews (23) from the bearing cover (28).
4. Position the housing against a bench block and hit the end of the output shaft (8) with a soft face hammer to remove the entire output shaft assembly with the bearing cover (28).
5. Remove the two pipe plugs (22) from the bearing cover (28) to expose the ball bearing assembly within the cover.
6. Using a 1/4" punch and alternating between the two holes drive the bearing and output shaft assembly from the bearing cover (28).
7. Using a bearing puller, remove the rear bearing (31) by grabbing the drag brake plate (33) and removing both pieces. The bronze disk (1) can be removed.
8. Insert four 1/4 - 20 capscrews into the drag brake rotor (2) until they just touch the back of the bell gear. Using an "X" pattern screw the capscrews in at 1/4 turn intervals until the brake rotor is free of the output shaft (8).
9. The piston and clutch pack may be serviced without removal of the drag brake. Using snap ring pliers, remove the snap ring (17) located on the output shaft end while gently pushing on the piston cup (16).
10. Pull the piston cup (16) from the shaft and the piston (14) will go with it.
11. Tap the piston cup on a wood surface to remove the piston.
12. Remove the spring (12). The clutch friction discs (10), spacer discs (11) and clutch hub (9) can be removed by pointing the shaft end down.
13. With the drag brake removed, the snap rings (3 & 4) on this end of the bell gear can be removed with snap ring pliers. This allows the bell gear (6) to be removed towards the closed end. The internal bearing (7) of the bell gear can be removed.

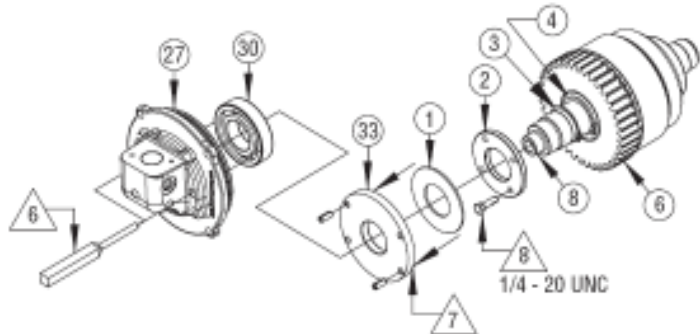

REASSEMBLY PROCEDURE

14. The reassembly of the unit is made in reverse of the disassembly. The re-use of seals, o-rings and snap rings are not recommended. See page (5) for gasket and rebuild kits.
15. Be sure to lubricate all o-rings and bearings upon installation. Torque all the capscrews to the appropriate values or to the following values: 5/16" Capscrews - 18 Ft. Lb.; 3/8" Capscrews - 36 Ft. Lb.; 1/4" Set Screw 9 Ft. Lb.
16. The input gear (38) is replaced as a set which includes the Base gear (36), cone spacer (37) and bearings (35). Slide this sub assembly into the housing to line up the idler shaft (36).
17. Insert the shim (39) between the bearing and the housing with the curved end towards the mounting pad (on the set screw side of the bearing races). Tap the idler shaft into the housing and through the bearing races.
18. Tap the idler shaft in the reverse direction so that it is flush with the bearing in this assembly. Insert the thickest shim (34) that can be installed by hand in the gap between the bearing and housing. Remove the shim (34) and select the next thickest shim and drive into the gap. Rotating the gear to make sure it easily rotates. The recommended bearing pre-load is .002" to .006" loose (the cone spacer sets this pre-load and the measurement is not required).
19. Tap the idler shaft (36) into position and install the set screw (40).

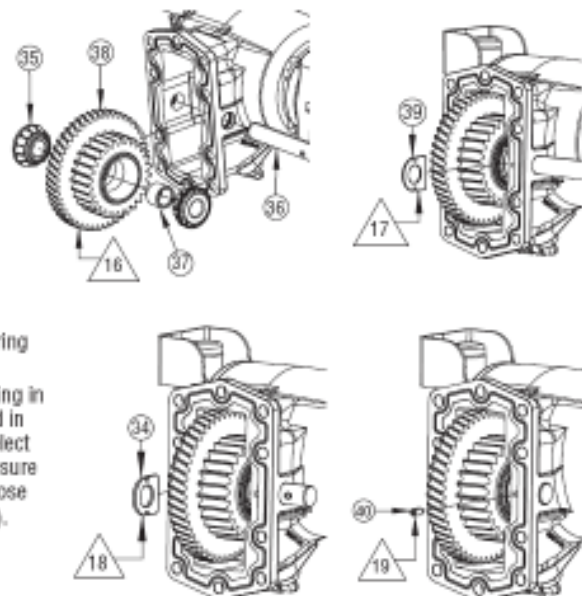

DROP-IN SOLENOID VALVE INSTALLATION

20. Valve is pushed into the housing cavity.
21. Use two 5mm capscrews (27) to mount the solenoid. Torque the capscrews to 2-3 Ft. Lb.

DRAG BRAKE ADJUSTMENT

22. When installing the rear cover, be sure to align the roll pins in the drag brake plate with holes in the rear cover.
23. After the cover has been attached to the housing, insert the springs (21) into the holes.
24. Insert the set screw (40) over the spring and turn the screw seven (7) full turns.
25. Follow the test and adjustment procedures in the CS24 owner's manual.

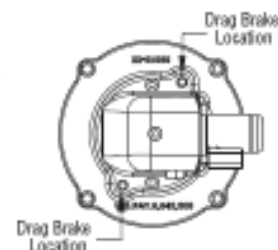

ACCESSORY KITS

INSTALLATION HOSE KITS

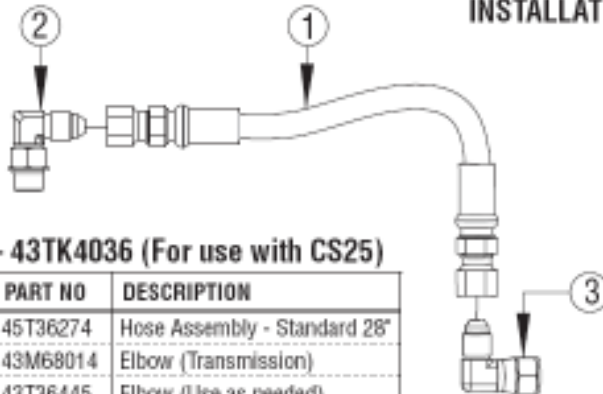

Hose Kit – 43TK4036 (For use with CS25)

ITEM	QTY	PART NO	DESCRIPTION
1	4	45T36274	Hose Assembly - Standard 28"
2	3	43M68014	Elbow (Transmission)
3	1	43T36445	Elbow (Use as needed)
N.S.	2	43T35867	Elbow
N.S.	1	43T36231	Tee Fitting

HOSE KITS

43TK3881-Standard 28"; 43TK3885-Top R.S. 4000 Series 57"(Optional); 43TK4545-Special 17" (optional); 43TK5163-Top R.S. 3000 Series 36" (optional)

ITEM	QTY	PART NO	DESCRIPTION
1	1	45T36274	Hose Assembly - Standard 28"
		45T36273	Hose Assembly - HD Top 57"
		45T39186	Hose Assembly - Special 17"
		45T38840	Hose Assembly - HD Top 36"
2	1	43M68014	Elbow (Transmission)
3	1	43T36445	Elbow -Use as needed (43TK3881 & 43TK4545 only)

BOLT KIT

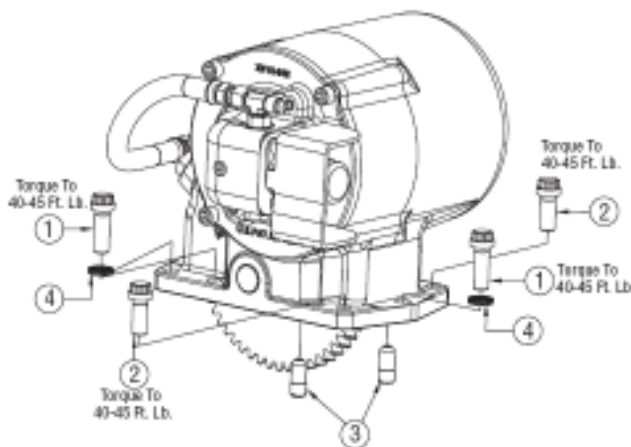

CS24/25 Bolt Kit – 20MK1001

ITEM	QTY	PART NO	DESCRIPTION
1	6	19T40266	12 Pt. Capscrew - 30mm
2	2	19T37727	12 Pt. Capscrew - 25mm
3	2	20T35779	Alignment Stud
4	2	21T40360	Nordlock Washer

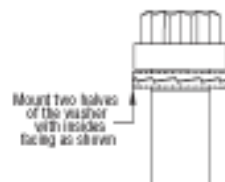
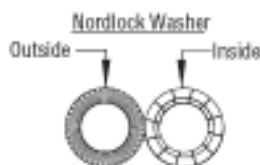

IMPORTANT: The CS24 includes the mounting kit, special shim/gasket, high pressure hose hookup kit, wiring harness, dash bracket kit and the installation instructions. The PTO is available with a pulse generator (pick-up) for use with the Muncie Digital Tachometer – 38MK2000 (request MP92-04) or use with the Muncie digital switch SPD-1001A to control the engagement or overspeed protection of the PTO. Contact your Muncie Application Specialist for assistance with these options.

SPEED SENSOR KIT – OPTION "U"

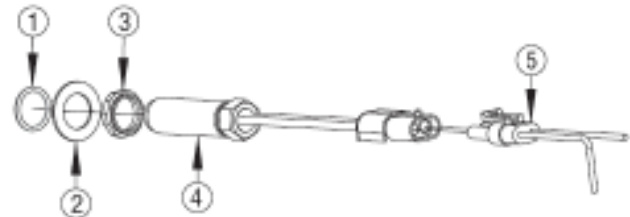

Speed Sensor Kit – 31TK3873

ITEM	QTY	PART NO	DESCRIPTION
1	1	21T41900	Seal Washer
2	1	21T35603	Flat Washer
3	1	21T35109	Jam Nut
4	1	31T35108	Mag Pickup
5	1	34MA1415	Wiring Harness

SOLENOID – CS25

12V Solenoid Assembly – 35T36092

24V Solenoid Assembly – 35T36447A

ITEM	QTY	PART NO	DESCRIPTION
1	1	22T39429	Nut
2	1	37T39088A	12V Coil
		37T38997A	24V Coil
3*	1	35T39577	Stem
4	2	12T39408	O-ring
5	1	N/A	Manifold Back

Dim A = 1.84" Dim B = 1.77"

*Item 3 is NOT sold separately

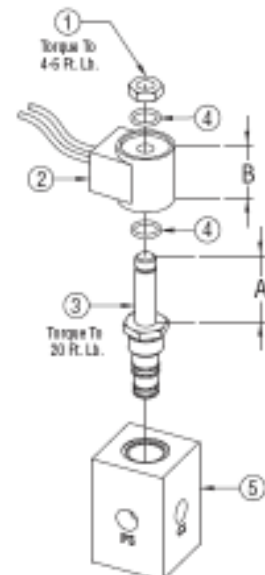

DIMENSIONS IN INCHES (MM)

"B" OUTPUT OPTION - 1 1/4" ROUND KEYED SHAFT

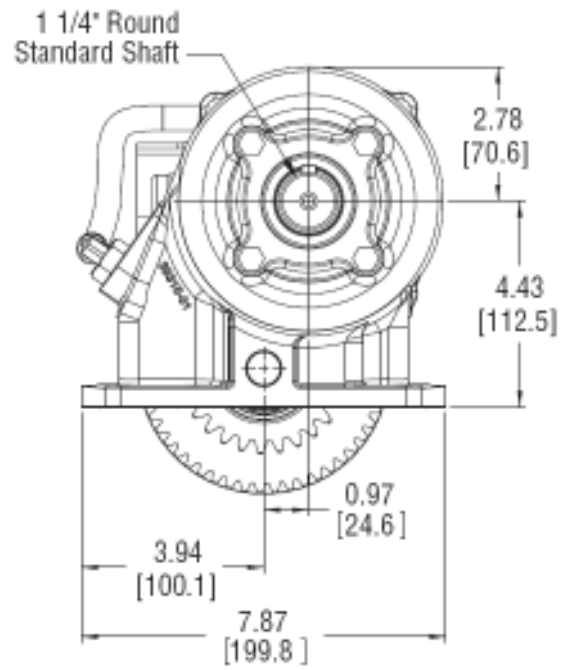
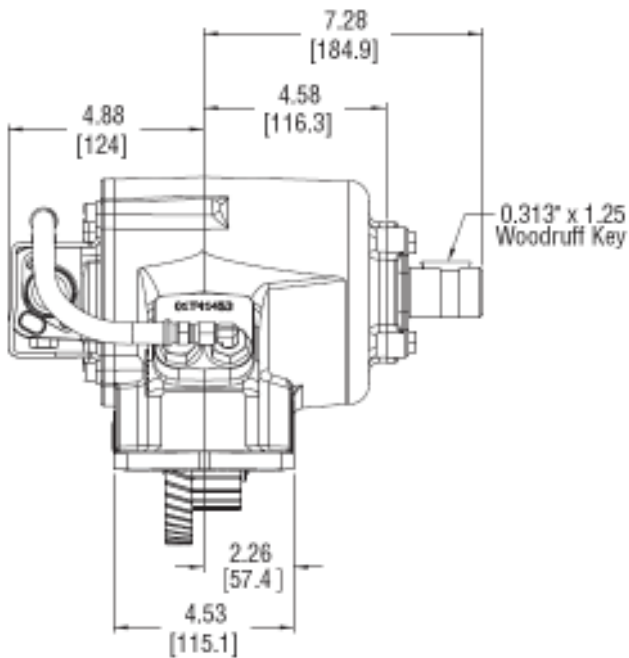

"C" OUTPUT OPTION - 1.3" - 20T W/ 1410 SERIES FLANGE

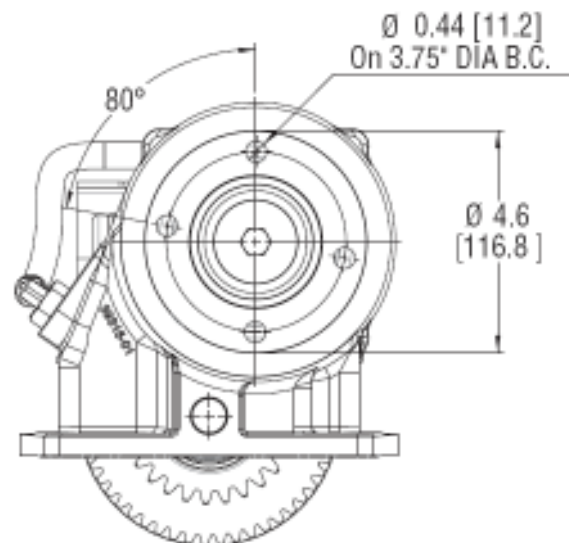
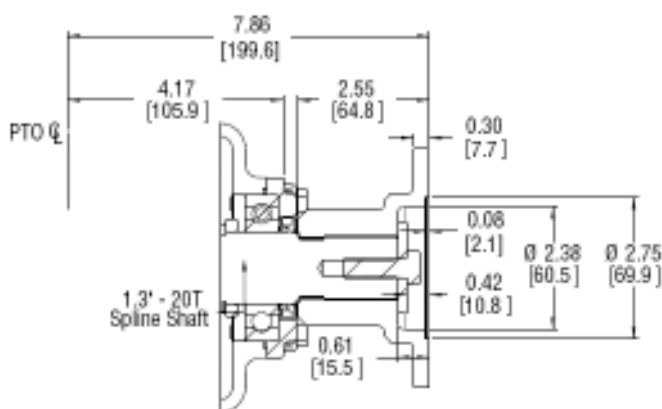

DIMENSIONS IN INCHES (MM)

"D" / "I" OUTPUT OPTION - DIN 5462 W/ 36MM - 8T

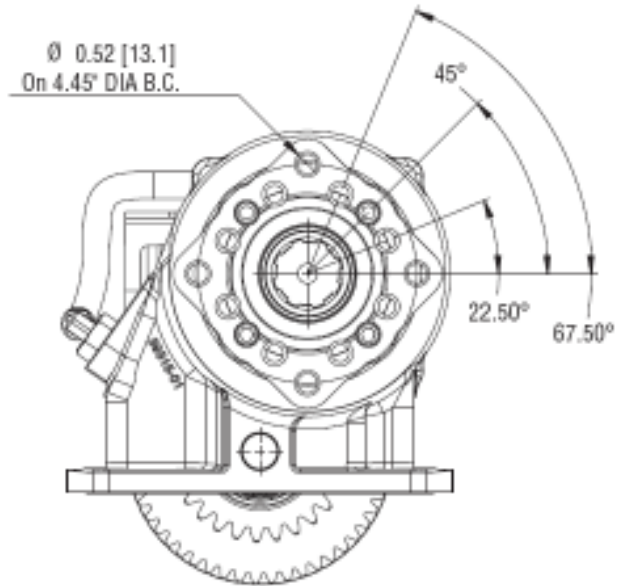
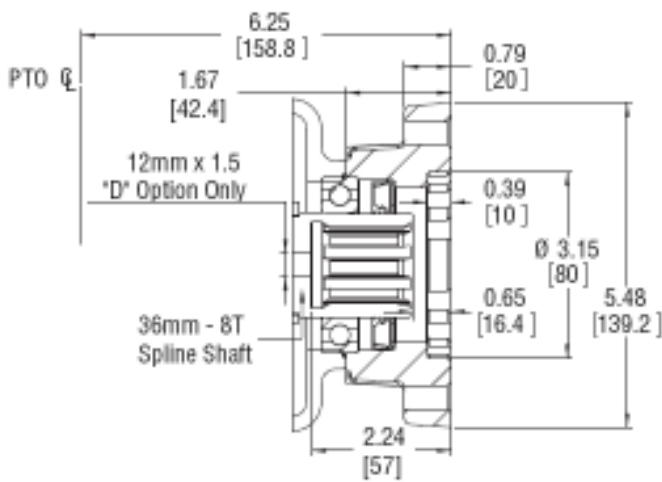

"G" OPTION - SPECIAL W/ 7/8" - 13T

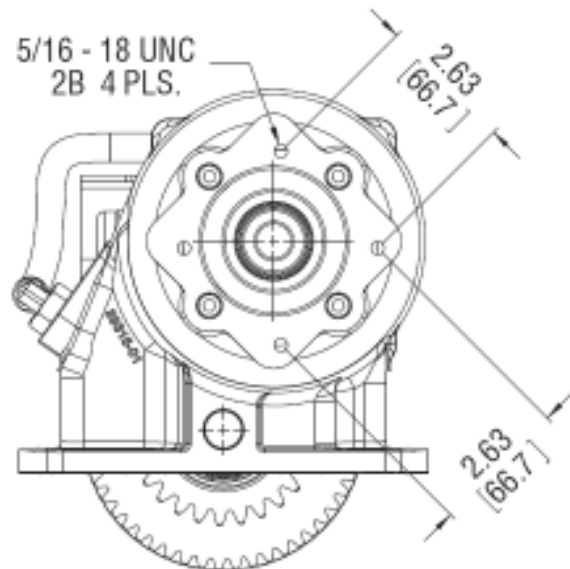
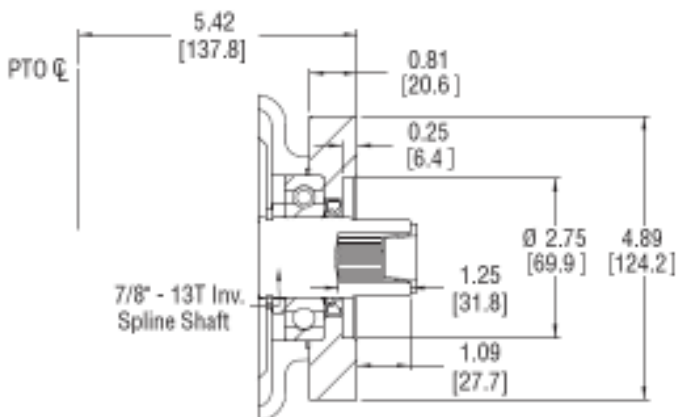

DIMENSIONS IN INCHES (MM)

“K” OPTION – SAE ‘B’ 2 & 4 BOLT W/ 7/8” – 13T
 “P” OPTION – SAE ‘B-B’ 2 & 4 BOLT W/ 1” – 15T
 “Z” OPTION – SAE ‘B’ 2 & 4 BOLT W/ 1.3” – 14T

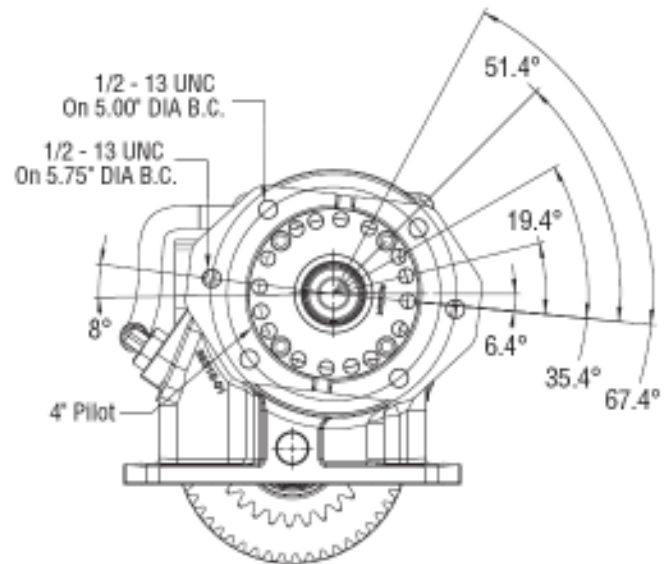
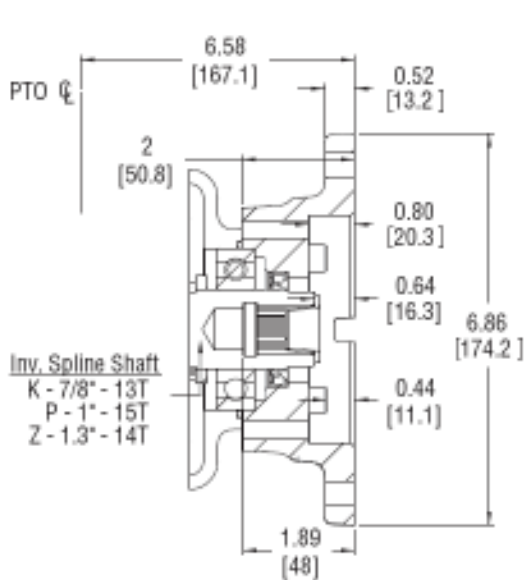

“Q” OUTPUT OPTION – SAE ‘A’ 2-BOLT W/ 7/8” – 13T
 “T” OUTPUT OPTION – SAE ‘A’ 2-BOLT W/ 3/4” – 11T

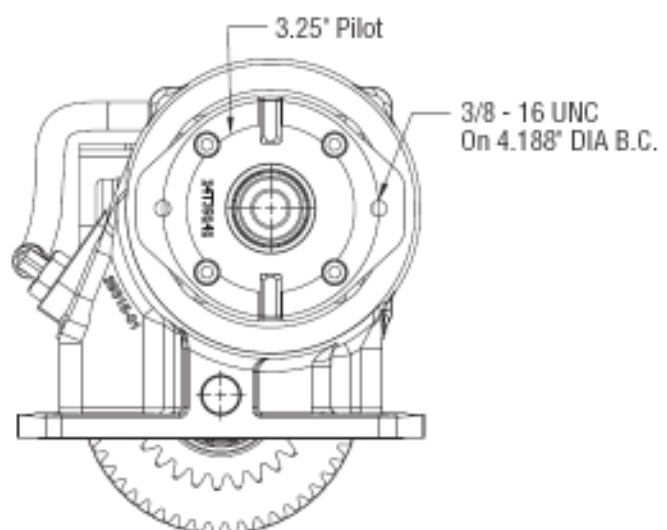
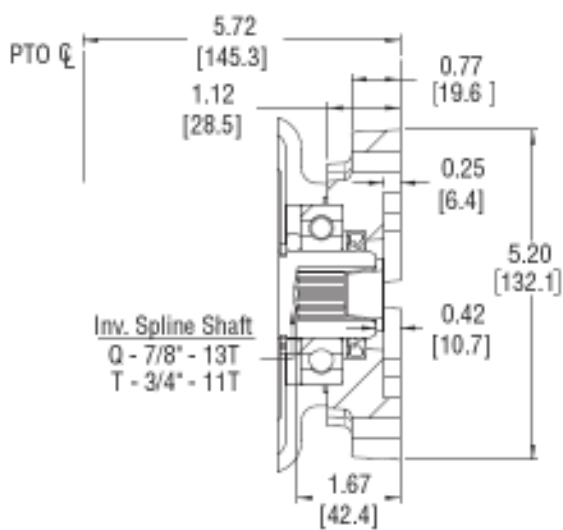

DIMENSIONS IN INCHES (MM)

"S" OUTPUT OPTION – SAE 'B' 2-BOLT W/ 7/8" – 13T

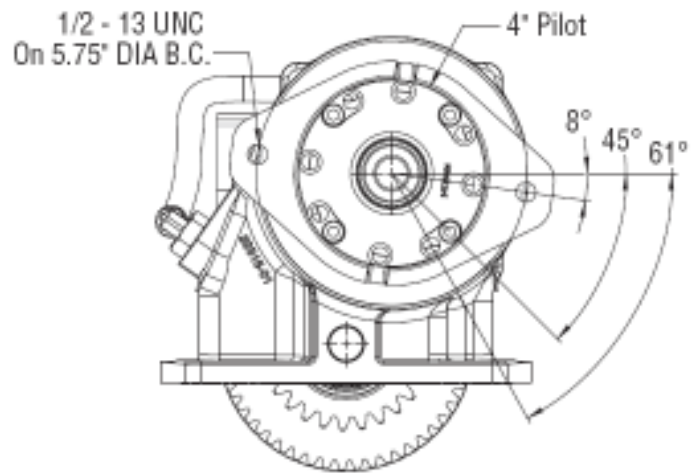
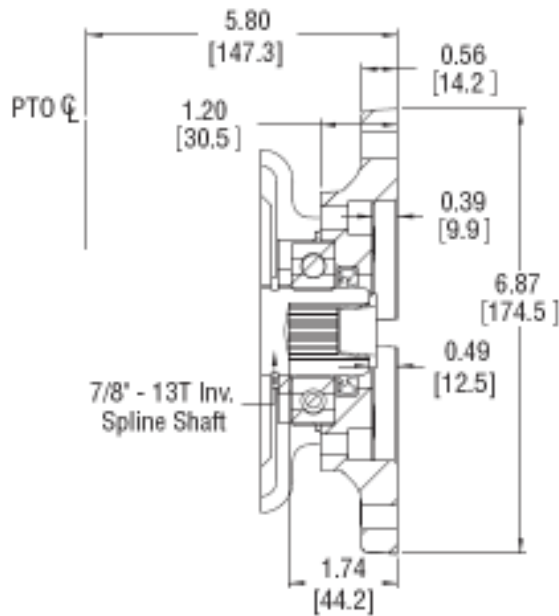

"2" OUTPUT OPTION – 1.3" – 20T W/ DIN COMPANION FLANGE

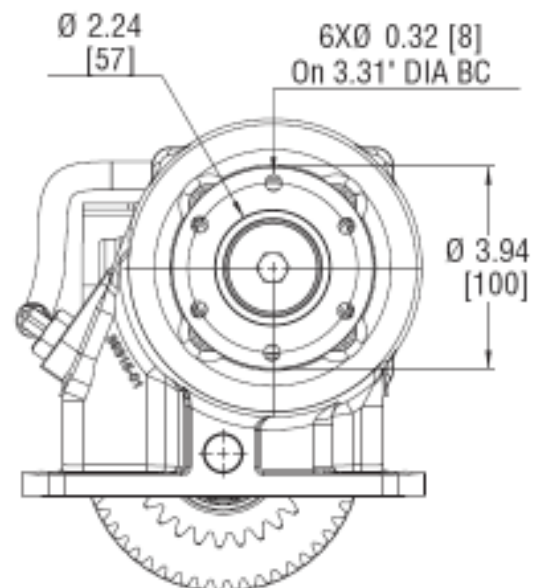
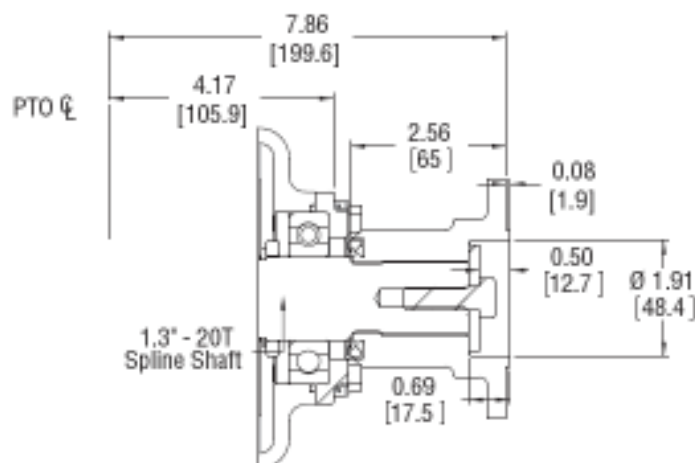

DIMENSIONS IN INCHES (MM)

"6" OUTPUT OPTION – SAE 'B' 2 BOLT W/ 7/8" – 13T

